



## LNK-AI

# Analog Input Peripheral Device Operation Manual

Rev B | 2017.05

[www.critical-environment.com](http://www.critical-environment.com)



### ELECTRICAL

Power Requirements	24 VDC (from daisy-chain wire run from controller)
Power Consumption	0.7 Watts (power consumption of LNK-AI only)
Circuit	Configurable microprocessor
Fuse	Automatic resetting thermal

### INPUT / OUTPUT

Input	Four 4 - 20 mA or 0-10 volt analog input Modbus® RS-485
Communication	Modbus ID: 50 (default, configurable) Baud Rate: 19,200 (default, configurable)

### ENVIRONMENTAL

Operating Temperature	-20°C to 40°C (-4°F to 104°F)
-----------------------	-------------------------------

~5~

### INTRODUCTION

The LNK-AI Analog Input Peripheral Device adds four channels of 4 - 20 mA or 0 - 10 volt analog inputs to a Modbus® network configured with an FCS Flexible Control System Controller.

The LNK-AI is designed to receive an analog signal from one to four transmitters and communicates back to the FCS using Modbus® RS-485. The FCS monitors the connection and will indicate a loss of communications.

Ideal for large applications to create an efficient distribution network of specialized gas detection devices with fewer wires running directly from the controller.

### Key Features

- » Four 4-20 mA or 0-10 volt analog input channels
- » Power LED indicator
- » Standard Modbus® RS-485 RTU
- » Scaling and zoning capabilities supported by the FCS
- » Configurable default settings for any interruption in communication
- » Standard water / dust tight, corrosion resistant enclosure (drip proof)

~2~

### CERTIFICATION

Model: LNK-AI  
S/N: LNKAI1603B00001  
Rating: 24 VDC, 1W, Class 2  
Max Temp: -20°C to 40°C (-4°F to 104°F)



CERTIFIED FOR ELECTRIC SHOCK & ELECTRICAL FIRE HAZARD ONLY. LA CERTIFICATION ACNOR COUVRE UNIQUEMENT LES RISQUES DE CHOC ELECTRIQUE ET D'INCENDIE D'ORIGINE ELECTRIQUE.

Conforms to: CSA-C22.2 No. 205-12, CSA-C22.2 No. 61010-1-12  
UL508 (Edition 17):2007, UL 61010-1 (Edition 3)

Conforms to: EMC Directive 2004/108/EC  
EN 61010-1:2010

Conforms to: FCC. This device complies with Part 15 of the FCC Rules. Operation is subject to the following two conditions: (1) This device may not cause harmful interference, and (2) this device must accept any interference received, including interference that may cause undesired operation.

~6~

The FCS Flexible Control System can accommodate up to a maximum of 60 analog inputs made up of different combinations of LNK-AI peripheral devices and internal -AI options. The maximum number of LNK-AI devices that can be attached to the FCS is fifteen. However, that maximum will change depending on whether one or two of the internal -AI options are installed.

Analog Input Options (on FCS)	Maximum # of LNK-AI's
No internal -AI option (0 internal analog inputs)	15 (60 remote analog inputs)
One internal -AI option (4 internal analog inputs)	14 (56 remote analog inputs)
Two internal -AI options (8 internal analog inputs)	13 (52 remote analog inputs)

**NOTE:** Depending on the number of devices attached to the gas detection system, additional power supplies (RPS-24VDC) and/or network extenders (LNK-XT) may be required. If after reading through this manual, you have any questions, please do not hesitate to contact our service department for technical support.

### Critical Environment Technologies Canada Inc.

Unit 145, 7391 Vantage Way, Delta, BC V4G 1M3

~3~

### Standard Enclosure Dimensions

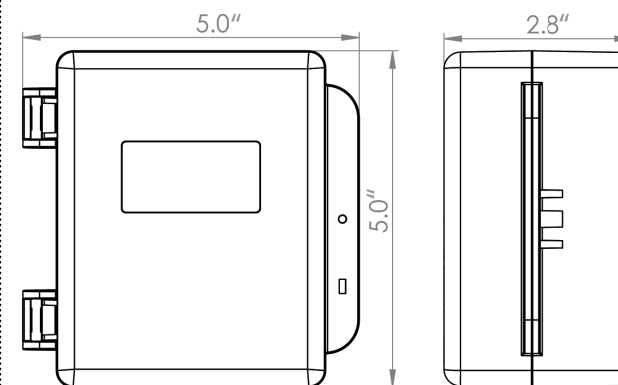

~7~

Toll Free: +1.877.940.8741

Telephone: 604.940.8741

service@cetci.com

Fax: 604.940.8745

[www.critical-environment.com](http://www.critical-environment.com)

This product must be installed and inspected by a qualified electrician or factory trained technician. This instrument has not been designed to be intrinsically safe. For your safety, **do not** use it in classified hazardous areas (explosion-rated environments).

### INSTRUMENT SPECIFICATIONS

#### Technical Specifications

MECHANICAL	
Enclosure	ABS / Polycarbonate, corrosion resistant, drip proof; Copper coated interior to reduce RF interference.
Weight	400 g (14 oz)
Size	5.0" x 5.0" x 2.8" (127 mm x 127 mm x 71 mm)
USER INTERFACE	
Indicator	LED green indicator for power

~4~

### Exterior Enclosure - Front



NUMBER	FEATURE	FUNCTION
1	Door Hinge	Secures door
2	Window for LED	Indicates device is powered on.
3	Door Screw	Secures door
4	Padlock Opening	For security padlock

~8~

## Interior System Layout

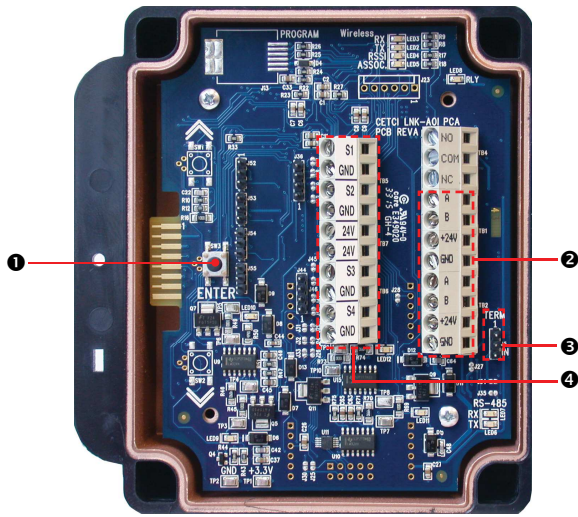

~9~

NUMBER	FEATURE	FUNCTION
1	Push Button	Used for changing the Modbus ID
2	Modbus® Connector (TB1 and TB2)	Terminals used to connect other devices in the Modbus® network
3	Jumper Bank 5 (J5)	Termination resistor. If this device is the last one in the network chain, a termination resistor should be connected by placing a jumper in the EN position
4	Analog Input Terminal Block (TB5, TB6 and TB7)	Terminals used to connect one to four 4-20 mA analog devices

~10~

## WIRING CONNECTIONS

All wiring should be run within properly grounded (earth or safety) conduit. Signal output and supply should be in shielded cable. The cable shield should be connected to earth ground at the controller/power supply that is providing power for the LNK-AI.

### Wiring Power Connections

The LNK-AI is a low voltage powered device. Any application of operating voltages higher than indicated in the specification may result in damage.

Double check wiring connections prior to powering the transmitter. Damage from incorrect wiring connections or from too much voltage applied is not covered under warranty.

External power to the LNK-AI must be supplied by a 24 VDC power supply or a Class 2 (or better) transformer and connected to the Modbus wiring terminal. The wiring should be 4-conductor shielded 16 awg stranded within conduit in a network wiring (daisy-chain) configuration.

**NOTE: WARRANTY VOID IF SOLID-CORE WIRE IS USED AT THE WIRING TERMINAL STRIP.** When using solid core wiring for distribution (in the conduit), use stranded wire pigtails 18 AWG within the enclosure to connect

~13~

to the circuit board. The rigidity of solid-core wire can pull a soldered terminal strip completely off a circuit board and this will not be covered under warranty.

### Wiring Example: 4-Wire VDC to FCS Controller

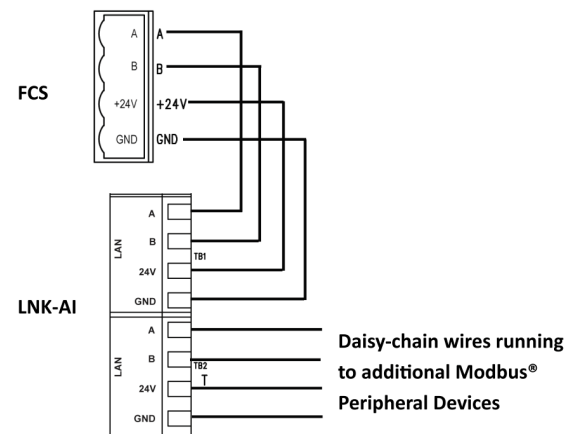

~14~

## Interior Enclosure - Base

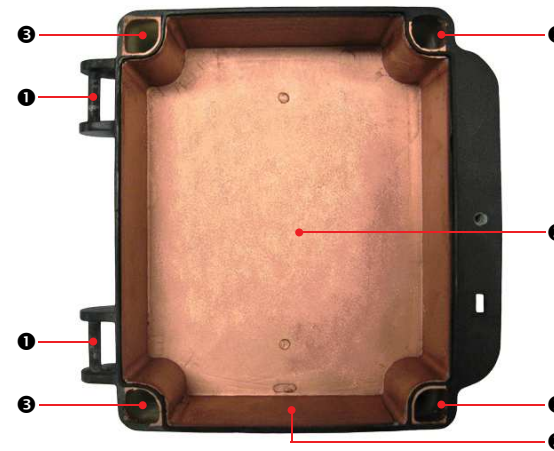

NUMBER	FEATURE
1	Door Hinge
2	1/2" Conduit Entry Knockout
3	Mounting Holes

~11~

~12~

## INSTALLATION

The LNK-AI should be installed on a flat vertical surface using the four 4.4 mm (0.175") diameter mounting holes provided to maintain water tight status.

Two 12.7 mm (½ in) conduit entry points are provided in the enclosure. Both are located in the enclosure base. One in the rear of the base and one on the bottom edge of the base. The clearance from the PCA to the base enclosure is 12.7 mm (½ in). **Do not use a conduit connector that has more than 12.7 mm (½ in) of thread length.**

**NOTE:** When mounting the enclosure, allow enough room to allow the end user to open the door fully to access the wiring terminal.

The LNK-AI is intended for indoor use and should be protected from extreme weather conditions. The LNK-AI requires no assembly and virtually no maintenance other than ensuring that excess water or dust is not somehow entering the enclosure and physically damaging the circuit board or internal components. There are no serviceable or replaceable elements or components in this device.

## Wiring Example: Analog Input Wiring Connection

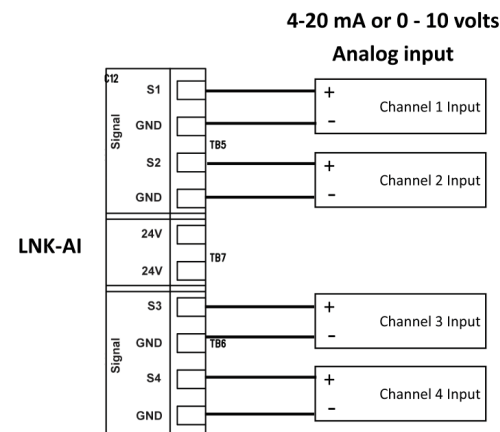

© 2017 Critical Environment Technologies Canada Inc.  
Modbus® is a registered trademark of Gould Inc. Corporation.  
Data subject to change without notice.

~15~

**Critical Environment Technologies Canada Inc.**  
Unit 145, 7391 Vantage Way, Delta, BC, V4G 1M3, Canada  
Toll Free: +1.877.940.8741  
Tel: +1.604.940.8741  
Fax: +1.604.940.8745  
[www.critical-environment.com](http://www.critical-environment.com)



~16~