

Installation Manual



Rev. B | 2022.03

ESH-A Remote Sensor



www.critical-environment.com

TABLE OF CONTENTS

1 POLICIES	4
1.1 Important Note	4
1.2 Warranty Policy	5
1.3 Service Policy	5
1.4 Copyrights	6
1.5 Disclaimer	6
1.6 Revisions	7
2 INTRODUCTION	8
2.1 General Description	8
2.2 Key Features	9
3 INSTRUMENT SPECIFICATIONS	9
3.1 Technical Specifications	9
3.2 Standard Enclosure Dimensions	12
4 SENSOR SPECIFICATIONS	13
4.1 List of Available Remote Sensors	13
5 FEATURES & FUNCTIONS	14
5.1 Exterior Enclosure	14
5.2 Interior System Layout	15
6 INSTALLATION	16
6.1 General Safety Warnings	17
6.2 Protection Against Electrical Risks	17
6.3 Protection Against Mechanical Risks	18
6.4 System Installation	19
6.4.1 Wet Environment Considerations	19
6.4.2 EMI and RF Interference Considerations	20

6.5 Sensor Mounting Heights.....	20
6.6 Enclosure Mounting Components	22
6.6.1 Enclosure Base.....	22
6.6.2 Enclosure Bottom	23
6.7 Wiring Connections.....	23
6.7.1 Wire Gauge vs Run Length by CETCI Device.....	25
7 SYSTEM OPERATION.....	26
7.1 Fault Detection	26
7.2 Selecting the Output Signal	27
8 CALIBRATION	27
8.1 Zero Calibration of a Responsive Sensor	27
8.2 Zero Calibration of a New or Replacement Sensor.....	28
9 ACCESSORIES	28
9.1 Splash Guard.....	28
9.2 Calibration Adapter Clip “Cal Clip”	29
9.3 Metal Protective Guard	29
9.4 Calibration Kit.....	30
10 MAINTENANCE	30
11 TROUBLE SHOOTING.....	31

1 POLICIES

1.1 Important Note

Read and understand this manual prior to using this instrument. Carefully read the warranty policy, service policy, notices, disclaimers and revisions on the following pages.

This product must be installed by a qualified electrician or factory trained technician and according to instructions indicated in this manual. This instrument should be inspected and calibrated regularly by a qualified and trained technician.

This instrument has not been designed to be intrinsically safe. For your safety, **do not** use it in classified hazardous areas (explosion-rated environments).

INSTRUMENT SERIAL NUMBER:

PURCHASE DATE:

PURCHASED FROM:

1.2 Warranty Policy

Critical Environment Technologies Canada Inc. warrants the products we manufacture (excluding sensors, battery packs, batteries, pumps, and filters) to be free from defects in materials and workmanship for a period of two years from the date of purchase from our facility. Sensors are consumable items and once they leave our factory, we cannot reuse or resell them. As such, all sensor sales are final. Should the sensor itself be faulty, there is a one-year pro-rated warranty that would apply from the date of purchase from our facility.

The warranty status may be affected if the instrument has not been used and maintained as per the instructions in the manual or has been abused, damaged, or modified in any way. The product is only to be used for the purposes stated in the manual. Critical Environment Technologies is not liable for auxiliary interfaced equipment or consequential damage.

Prior to shipping equipment to CETCI, contact our office for an RMA #. All returned goods, regardless of reason, must be accompanied with an RMA number. Please read our Warranty and Returns Policy and follow our RMA Instructions and Form.

Due to ongoing research, development, and product testing, the manufacturer reserves the right to change specifications without notice. The information contained herein is based on data considered accurate. However, no warranty is expressed or implied regarding the accuracy of this data.

1.3 Service Policy

CETCI maintains an instrument service facility at the factory. Some CETCI distributors / agents may also have repair facilities; however, CETCI assumes no liability for service performed by anyone other than CETCI personnel.

Repairs are warranted for 90 days after date of shipment (sensors have

individual warranties). Should your instrument require non-warranty repair, you may contact the distributor from whom it was purchased, or you may contact CETCI directly.

Prior to shipping equipment to CETCI, contact our office for an RMA #. All returned goods, regardless of reason, must be accompanied with an RMA number. Please read our Warranty and Returns Policy and follow our RMA Instructions and Form.

If the product is deemed repairable, for liability reasons, CETCI will perform all necessary repairs to restore the instrument to its full operating condition.

1.4 Copyrights

This manual is subject to copyright protection; all rights are reserved. Under international and domestic copyright laws, this manual may not be copied or translated, in whole or in part, in any manner or format, without the written permission of CETCI.

Modbus® is a registered trademark of Gould Inc. Corporation.
BACnet® is a registered trademark of American Society of Heating, Refrigeration and Air Conditioning (ASHRAE).

1.5 Disclaimer

Under no circumstances will CETCI be liable for any claims, losses or damages resulting from or arising out of the repair or modification of this equipment by a party other than CETCI service technicians, or by operation or use of the equipment other than in accordance with the printed instructions contained within this manual or if the equipment has been improperly maintained or subjected to neglect or accident. Any of the forgoing will void the warranty.

Under most local electrical codes, low voltage wires cannot be run within the same conduit as line voltage wires. It is CETCI policy that all wiring of our products meet this requirement. It is CETCI policy that all wiring be within properly grounded (earth or safety) conduit.

1.6 Revisions

This manual was written and published by CETCI. The manufacturer makes no warranty or representation, expressed or implied including any warranty of merchantability or fitness for purpose, with respect to this manual.

All information contained in this manual is believed to be true and accurate at the time of printing. However, as part of its continuing efforts to improve its products and their documentation, the manufacturer reserves the right to make changes at any time without notice. In addition, due to improvements made to our products, there may be information in this manual that does not exist in the version of the product the user has. Should you detect any error or omission in this manual, or should you want to inquire regarding upgrading the device's firmware, please contact CETCI at the following address:

Critical Environment Technologies Canada Inc.

Unit 145, 7391 Vantage Way, Delta, BC, V4G 1M3, Canada

Toll Free: +1.877.940.8741

Telephone: +1.604.940.8741

Email: marketing@cetci.com

Website: www.critical-environment.com

In no event will CETCI, its officers or employees be liable for any direct, special, incidental or consequential damages resulting from any defect in any manual, even if advised of the possibility of such damages.

2 INTRODUCTION

2.1 General Description

Thank you for purchasing our ESH-A Remote Sensor. The ESH-A Remote Sensor offers flexible location monitoring of combustible or PID TVOC gases in non-hazardous, non-explosion rated commercial and light industrial applications.

The ESH-A Remote Sensor communicates with a controller or transmitter using a current loop into a 100 ohm load or a voltage signal of 0.40 to 2 volts.

Each ESH-A is given the same serial number as the device it is being connected to. Make sure to connect the ESH-A to the controller or transmitter that has the same serial number or the system won't work and the factory calibration will be void.

The sensor is protected in our standard water/dust tight, corrosion resistant ABS/poly-carbonate enclosure which also provides easy mounting components. An optional splash guard may be installed to further protect the remote sensor in water spray or wash down applications.

All ESH-A Remote Sensors operate by diffusion. The sensors utilized in this device are accurate enough to measure to Occupational Health & Safety (OHS) hazardous levels for toxic gases.

If after reading through the manual, you have any questions, please do not hesitate to contact our Technical Service Department for technical support at help@cetci.com or

Toll Free: +1.877.940.8741

Telephone: +1.604.940.8741

2.2 Key Features

- Single gas channel
- Allows remote location monitoring of gases; ideal for applications that require a sensor mounted at a visually awkward height like near the ceiling or close to the floor
- 12 - 24 VDC power (nominal)
- Current or voltage output signal
- Standard water / dust tight, corrosion resistant enclosure (drip proof). With the optional splash guard installed it is IP54 rated, for splash or hose-down applications.
- RoHS compliant circuit boards
- Easy to install and maintain

3 INSTRUMENT SPECIFICATIONS

3.1 Technical Specifications

GAS TYPE

Combustible (catalytic)	Acetylene (C_2H_2), Hydrogen (H_2), Methane (CH_4), Propane (C_3H_8),
PID	TVOCs
Infrared	Propane (C_3H_8)

MECHANICAL

Enclosure	ABS / Polycarbonate, IP54 rated with optional splash guard installed. Copper coated interior to reduce RF interference.
Weight	340 g (12 oz)
Size	127 mm x 127 mm x 53 mm / 5.0" x 5.0" x 2.1"

ELECTRICAL

Power Requirement	12 - 24 VDC, 1W, Class 2
Outputs	current or voltage
Wiring	VDC four conductor shielded 14 - 18 awg (or larger) stranded within conduit (refer to Section 6.7.1 <i>Wire Gauge vs. Run Length</i>)

ENVIRONMENTAL

Operating Temperature	-20°C to 40°C / -4°F to 104°F
Operating Humidity	15 - 90% RH non-condensing

COMPATIBLE WITH THESE CETCI PRODUCTS

Controllers	SCC Self Contained DCC Dual Channel
-------------	--

Transmitters	CGAS-A Detector Analog CGAS-D Detector Digital LPT-A Analog LPT-P Car Park Digital LPT-M Modbus LPT-B BACnet
--------------	---

CERTIFICATION

Model: ESH-A-XXXX

S/N: same serial# as controller or transmitter connected to

Rating: 12 - 30 VDC, 1W, Class 2

CERTIFIED FOR ELECTRIC SHOCK & ELECTRICAL FIRE HAZARD ONLY. LA CERTIFICATION ACNOR COUVRE UNIQUEMENT LES RISQUES DE CHOC ELECTRIQUE ET D'INCENDIE D'ORIGINE ELECTRIQUE.

Conforms to: CSA-C22.2 No. 205-12, UL508 (Edition 17):2007

Conforms to: EMC Directive 2004/108/EC, EN 50270:2006, Type 1, EN61010

Conforms to: FCC. This device complies with part 15 of the FCC Rules,

Operation is subject to the following two conditions: (1) This device may not cause harmful interference, and (2) this device must accept any interference received, including interference that may cause undesired operation.



3.2 Standard Enclosure Dimensions

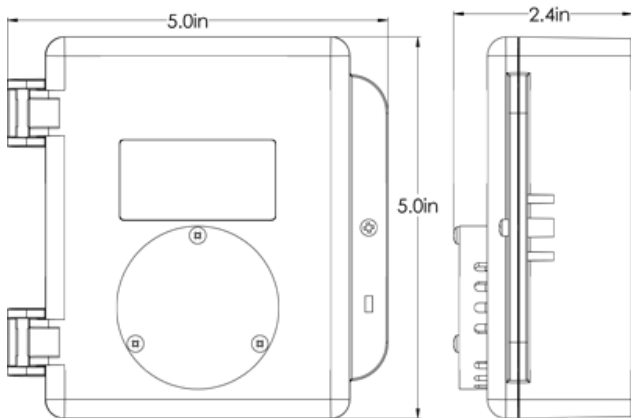

Above dimensions are shown with optional splash guard. Without splash guard, thickness is 53.34 mm (2.1"). The area required for enclosure door to be open 90 degrees is 155.7 mm (6.13") or 243.84 mm (9.6") for fully open. With the splash guard, the enclosure has an IP54 rating.

NOTE: Response time will be slower with a splash guard installed.

4 SENSOR SPECIFICATIONS

4.1 List of Available Remote Sensors

ESH-A Remote Sensors - Combustible (Catalytic)

Acetylene (C ₂ H ₂)	ESH-A-CC2H2-100	0 - 100% LEL	~5 years
Hydrogen (H ₂)	ESH-A-CH2-100	0 - 100% LEL	~5 years
Methane (CH ₄)	ESH-A-CH4-100	0 - 100% LEL	~5 years
Propane (C ₃ H ₈)	ESH-A-C3H8-100	0 - 100% LEL	~5 years

ESH-A Remote Sensors - TVOC PID

TVOC PID	ESH-A-SPL	0 - 30 ppm	usage / application dependent
TVOC PID	ESH-A-SPH	0 - 300 ppm	

ESH-A Remote Sensors - Infrared

Propane (C ₃ H ₈)	ESH-A-JET	0 - 100% LEL	~8 years
--	-----------	--------------	----------

5 FEATURES & FUNCTIONS

5.1 Exterior Enclosure



NUMBER	FEATURE	FUNCTION
1	Door Hinge	Secures door
2	Gas Type	Indicates sensor gas type
3	Door Screw	Secures door
4	Sensor Opening	Allows gas diffusion into sensor
5	Padlock Opening	For security padlock

5.2 Interior System Layout

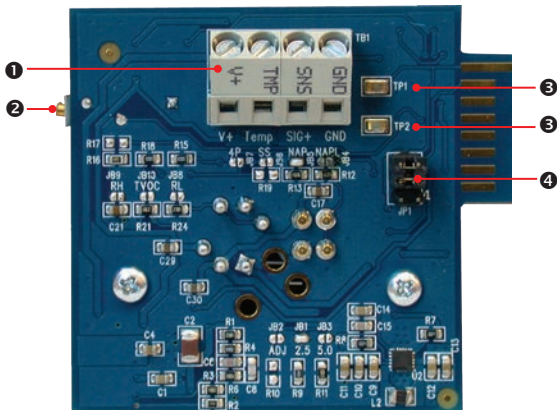

NUMBER	FEATURE	FUNCTION
1	Wiring Terminal	<p>V+ is the 12 - 24 VDC power supply</p> <p>TMP/Temp is for the temperature signal output to the controller/transmitter</p> <p>SNS/SIG+ is the signal output to the controller/transmitter</p> <p>GND is the ground connection</p>

2	POT RN1 (Potentiometer)	Used for Zero calibration of a new or replacement sensor. TP1 and TP2 calibrate to 0.40 VDC with Null gas applied.
3	Test Points: TP1 & TP2	For adjusting a new or replacement sensor to Zero. TP1 and TP2 calibrate to 0.40 VDC with Null gas applied.
4	JP1 Jumper Bank Pin 1 - internal load resistor Pin 2 - resting position Pin 3 - external connection	JP1-1 and JP1-2 are used to calibrate a new sensor JP1-1 and JP1-3 are used to set the voltage output JP1-2 and JP1-3 are used to set the current output

6 INSTALLATION

The ESH-A is not a standalone sensor, it must be connected to a CET Controller or Transmitter. **Each ESH-A is given the same serial number as the device it is being connected to. Make sure to connect the ESH-A to the controller or transmitter that has the same serial number or the system won't work and the factory calibration will be void.**

If the device is not installed within two weeks of delivery, the sensor may require a longer warm up time to stabilize (approximately 48 hours) and provide accurate readings.

NOTE: CETCI suggests that upon power-up, all sensors be left to warm up for 24 - 48 hours prior to considering the gas readings to be accurate.

NOTE: All sensors are calibrated in the factory before they are shipped

and should not require calibration at the time of a routine installation or replacement.

NOTE: Temperature affects calibration. It is important to ensure the gas is at the appropriate temperature during calibration. If the sensor is being used in an extreme temperature range, calibration should be done in that same temperature range.

A bump test will help you determine if a sensor requires calibration. If the sensor still does not respond as it should after a successful calibration, it probably requires replacing.

6.1 General Safety Warnings

The ESH-A Remote Sensor is intended for indoor use, permanently mounted at a height that is appropriate for the type of gas being monitored. See Section 6.5 *Sensor Mounting Heights*. The ESH-A Remote Sensor should be protected from extreme weather conditions.

The ESH-A Remote Sensor requires no assembly and virtually no maintenance other than regular calibration of the sensor and ensuring that excess water or dust is not somehow entering the enclosure and physically damaging the circuit board or internal components. There are no serviceable elements other than the calibration instructions outlined in this manual. There are no replaceable components except the sensors.

6.2 Protection Against Electrical Risks

Disconnect all power before servicing. Power is supplied by the controller or transmitter and may have a building installed circuit breaker / switch that is suitably located and easy to access when servicing (disconnecting power to the controller or transmitter). Appropriate markings should be visible at the circuit breaker / switch that is supplying power to the controller or transmitter.

This device may interfere with pacemakers. Modern pacemakers have built-in features to protect them from most types of interference produced by other electrical devices you might encounter in your daily routine. If you have a pacemaker, follow your healthcare provider's instructions about being around this type of equipment.

6.3 Protection Against Mechanical Risks

The door of the enclosure can be removed if absolutely necessary to facilitate installation of the base but it is not recommended on this version. Extreme care and caution must be exercised when removing the door to avoid damaging the hinges. The door should only be removed when absolutely required. Any damage occurring from door removal procedure will not be covered under warranty.

Simply grasp the door with one hand, being careful not to make contact with any of the internal components (circuit board), grasp the base with your other hand. Tug on the base and pull straight apart. **DO NOT TWIST.** The section of the hinges located on the base should "snap" apart from the part of the hinges located on the door.

After installation, simply locate the lid hinges over the installed base hinges and pull toward you. The hinges should easily "snap" back into place.

The enclosure has one screw securing the door to the base for electrical safety and provides an opening to allow the user to apply a padlock or tie wrap if they desire the transmitter to be locked. See Section 5.1 *Exterior Enclosure*.

Be aware that the hinged door that could potentially pinch fingers and the sharp edges and/or jumper pins on the board could potentially prick or cut fingers if not handled carefully.

6.4 System Installation

The ESH-A Remote Sensor should be installed on a flat vertical surface using the four 4.4 mm (0.175") diameter mounting holes provided to maintain water tight status. Care should be taken to ensure that the face of the enclosure and specifically the vent opening is not obstructed in order to maximize the sensor's exposure to the environment being monitored.

Two 12.7 mm ($\frac{1}{2}$ ") conduit entry points are provided in the enclosure. Both are located in the enclosure base. One in the rear of the base and one on the bottom edge of the base. See Section 6.6 *Enclosure Mounting Components*.

The clearance from the PCA to the base enclosure is 12.7 mm ($\frac{1}{2}$ "). **Do not use a conduit connector that has more than 12.7 mm ($\frac{1}{2}$ ") of thread length.**

NOTE: When mounting the enclosure, allow enough room to allow the end user to open the door fully to access the internal adjustments.

6.4.1 Wet Environment Considerations

If the ESH-A is to be installed in a potential hose-down application or any application whereby liquid could be directed towards the sensor opening, the ESH-A should be ordered with an optional attached splash guard (factory installed).

If used in a wet or wash down application, the conduit hub entering the ESH-A enclosure must be liquid tight type.

Any water or physical damage to the transmitter that occurs from the installer drilling their own installation holes will not be covered under warranty.

6.4.2 EMI and RF Interference Considerations

All electronic devices are susceptible to EMI (Electromagnetic Interference) and RFI (Radio Frequency Interference). Our detectors have been designed to reduce the effects of these interferences and we meet CSA FCC and CE requirements for these type of devices. However there are still circumstances and levels of interference that may cause our equipment to respond to these interferences and cause them to react as if there has been gas detected. There are some installation procedures that will reduce the likelihood of getting faulty readings:

1. Locate the detectors and controllers out of the way from normal foot traffic and high energy equipment.
2. Confirm the devices are properly grounded using conduit and shielded cabling.
3. Inform operators and technical staff working in the surrounding area to be aware of these possible conditions and that two way radios, Bluetooth enabled devices, cell phones and other electrical equipment may interfere with the response of the gas detectors.

6.5 Sensor Mounting Heights

The sensor mounting height depends on the density of the gas relative to air. Heavier than air gases should be detected 15.24 cm (6") from the floor, lighter than air gas sensors should be placed on or near the ceiling, and gases which have a density close to that of air should have sensors installed in the "breathing zone" 1.22 - 1.83 m (4 - 6 ft) from the floor. The breathing zone refers to the area 1.22 - 1.83 m (4 - 6 ft) from the floor, where most human breathing takes place. This is a good default location for sensors, as many gases are often well dispersed in air.

Typical Mounting Height by Gas:

GAS TYPE	MOUNTING HEIGHT	COVERAGE (ft²)	COVERAGE (m²)
Acetylene (C ₂ H ₂) (combustible)	on or near the ceiling	5000	465
Hydrogen (H ₂) (combustible)	on or near the ceiling	5000	465
Methane (CH ₄) (combustible)	on or near the ceiling	5000	465
Propane (C ₃ H ₈) (combustible)	6 in (15 cm) from floor	3000	279
TVOCs (PID)	target gas dependent	3000	279
Propane (C ₃ H ₈) (infrared)	6 in (15 cm) from floor	3000	279

6.6 Enclosure Mounting Components

6.6.1 Enclosure Base

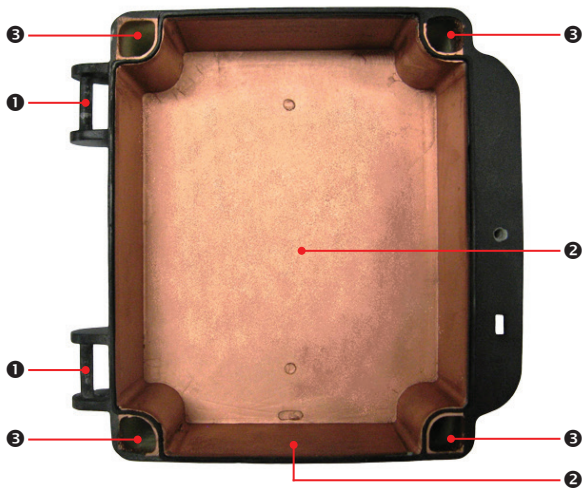
**NUMBER****FEATURE****1**

Door hinge

2

Conduit Entry Points 12.7 mm / 1/2 in diameter

-
- ③ Mounting Holes 4.47 mm / 0.175 in diameter
maximum head diameter 8 mm / 0.32 in, #8 or 4 mm
screw
-

6.6.2 Enclosure Bottom

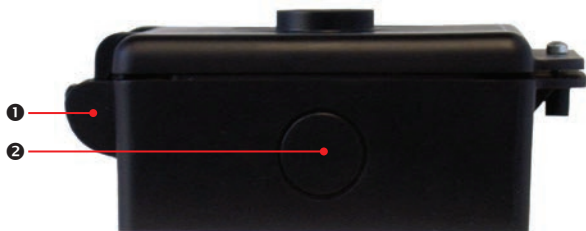

NUMBER	FEATURE
--------	---------

- | | |
|---|--|
| ① | Door hinge |
| ② | Conduit Entry Points 12.7 mm / 1/2 in diameter |
-

6.7 Wiring Connections

IMPORTANT: Each ESH-A is given the same serial number as the device it is being connected to. Make sure to connect the ESH-A to the controller or transmitter that has the same serial number or the system won't work and the factory calibration will be void.

The ESH-A Remote Sensor must be used with appropriately rated equipment. External 12 - 24 VDC power to the ESH-A is supplied by the controller or transmitter it is connected to.

The ESH-A Remote Sensor is a low voltage powered device. Any application of operating voltages higher than indicated in the specification may result in damage. Double check wiring connections prior to powering the system. Damage from incorrect wiring connections or from too much voltage applied is not covered under warranty.

All wiring should be run within properly grounded (earth or safety) conduit. Signal output and supply should be in shielded cable. The cable shield should be connected to earth ground at the controller/transmitter that is providing power for the ESH-A Remote Sensor.

Under most local electrical codes, low voltage wires cannot not be run within the same conduit as line voltage wires.

NOTE: WARRANTY VOID IF SOLID-CORE WIRE IS USED AT THE WIRING TERMINALS. The wiring terminal strips on the ESH-A Remote Sensor circuit board are mounted on a 30 degree angle, making the wiring connections easier to install.

When using solid core wiring for distribution (in the conduit), use stranded wire pigtailed 14 - 18 AWG within the enclosure to connect to the circuit board. The rigidity of solid-core wire can pull a soldered terminal strip completely off a circuit board and this will not be covered under warranty.

Four-conductor, 16 AWG stranded shielded cable is required for the ESH-A Remote Sensor wiring. This wiring should be run in a conduit, separate from the signal output, and should not exceed the cable lengths specified in this manual. The voltage at the remote sensor (Red V+ to Black GND) should be 12 - 24 VDC. If this voltage is not met after installation, the wrong gauge wire may have been used or the wiring run is too long.

6.7.1 Wire Gauge vs Run Length by CET Device

NOTE: Refer to the Operation Manual of the controller or transmitter you are connecting the ESH-A Remote Sensor to for specific wiring instructions.

TRANSMITTER / CONTROLLER	SUPPLY VOLTAGE (from transmitter / controller)	MAXIMUM LOAD (Wire + Termination Resistor) (ohms)	WIRE GAUGE (AWG)	MAXIMUM CABLE LENGTH
CGAS-A Analog Transmitter	12 - 24 VDC	100	16	15 m / 50 ft
CGAS-D Digital Transmitter	12 - 24 VDC	100	16	15 m / 50 ft
LPT-A Analog Transmitter	12 - 24 VDC	100	16	15 m / 50 ft
LPT-B BACnet Transmitter	12 - 24 VDC	100	16	61 m / 200 ft
LPT-M Modbus Transmitter	12 - 24 VDC	100	16	61 m / 200 ft
LPT-P Car Park Digital Transmitter	12 - 24 VDC	100	16	61 m / 200 ft
SCC Self Contained Controller	12 - 24 VDC	100	16	61 m / 200 ft
	90 - 240 VAC	100	16	61 m / 200 ft
DCC Dual Channel Controller	12 - 24 VDC	100	16	61 m / 200 ft
	12 - 24 VDC	100	16	61 m / 200 ft

7 SYSTEM OPERATION

The ESH-A is not a standalone sensor, it must be connected to a CET Controller or Transmitter. **Each ESH-A is given the same serial number as the device it is being connected to. Make sure to connect the ESH-A to the controller or transmitter that has the same serial number or the system won't work and the factory calibration will be void.**

Upon application of power, there is a warm-up period (typically five minutes, but varies with sensor type) the output signal is fixed at 4.0 mA (current) or 0.40 volts (voltage). After the warm up period, the system may exhibit gas alarm condition if the sensor has not completely stabilized during the warm up period. This is normal and the length of time the gas alarm exists is dependent upon the length of time since the unit was last powered up and the state of the environment it is installed in.

NOTE: A new or replacement sensor will require a warm-up period of 48 hours upon first installation /calibration. Refer to Section 8.2 *Zero Calibration of a New or Replacement Sensor*

During normal operation, the gas level will be reported through the current loop (or voltage) output back to the controller or transmitter.

7.1 Fault Detection

In the event of a problem with the measurement circuitry or dead or damaged sensor, the signal between the ESH-A Remote Sensor and the controller or transmitter may drop and the controller/transmitter may indicate a fault condition on the display (if equipped with one) or via the Fault LED. Normal operation will resume once the fault condition has been rectified.

7.2 Selecting the Output Signal

The default signal output mode is a current loop. Zero concentration gas will output 4.0 mA and full scale gas concentrations will depend on the sensor age and output.

The output can be changed to voltage (0.4 - 2.0 volt) **only if directed by CETCI**, by moving the jumper at JP1 from the JP1-1 to the JP1-3 position. The voltage signal will swing from 0.4 volts to indicate no gas detected, to 2.0 volts (depending on age of sensor) to indicate full scale gas detected.

8 CALIBRATION

There are two different processes for calibrating an ESH-A Remote Sensor. One process is for a properly functioning (responsive) sensor and the other is for a new or replacement sensor.

8.1 Zero Calibration of a Responsive Sensor

If the sensor does not need to be replaced and is responding correctly, the Zero and Span calibrations will need to be done at the controller or transmitter that the ESH-A is connected to.

Make sure both the Controller or transmitter and the ESH-A Remote Sensor are powered up and have warmed up for a 24 hour period prior to calibration. Place the Channel select jumper on the controller or transmitter on the channel assigned to the ESH-A and follow the instructions in the Calibration section of the Operation Manual for the controller or transmitter the ESH-A is connected to, **with the exception that the gas should be applied to the ESH-A sensor opening instead of the transmitter or controller's sensor opening.**

8.2 Zero Calibration of a New or Replacement Sensor

If a new replacement sensor has been installed, the ESH-A will require a Zero calibration of its sensor. This process will normally be required if the sensor has been replaced or there is concern that the sensor is not responding correctly. Power up the ESH-A Remote Sensor and leave it on; the new sensor should be allowed to warm-up for a 24 hour period prior to calibration.

1. Move the jumpers from their resting position to JP1-1 and JP1-2.
2. Apply the correct Null gas for the type of sensor installed, for a minimum of 2 minutes.
3. Attach a volt meter to TP1 and TP2.
4. Using the POT RN1 potentiometer (located on the left underside of the board), adjust the voltage to read 0.40 VDC.
5. Return the jumpers to their original positions.

9 ACCESSORIES

9.1 Splash Guard (p/n/: S)

The splash guard attaches to the front of the enclosure to protect the sensor during water spray or washdown applications. It is factory installed and when attached the enclosure meets IP54 standards.



NOTE: The splash guard will slow down the response time of the sensor.

9.2 Calibration Adapter Clip “Cal Clip” (p/n: CET-SGC)

To calibrate an ESH-A with a factory installed splash guard (Option -S), attach the Cal Clip around the splash guard. The small barb hose fitting accommodates standard or Teflon tubing of 1/8” (3.175 mm) ID and 3/16” (4.762 mm) ID. The Cal Clip must be removed during normal operation or else the gas readings will not be accurate.



9.3 Metal Protective Guard (p/n: SCS-8000-RSG)

The metal protective guard is made of heavy duty metal and helps to protect against abrasive damage, theft and vandalism to the transmitters. It is made from 16-gauge powder coated steel and has 13 mm (½”) square openings in the front to allow gas and air to flow through to the sensor. With four slotted mounting holes, installation and removal for equipment servicing is easy.

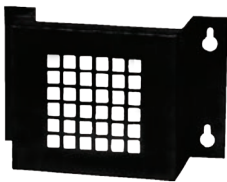

Enclosure	16 gauge powder coated steel
Weight	800 g (28 oz)
Size	178 mm W x 160 mm H x 91 mm D 7.0" W x 6.3" H x 3.6" D

9.4 Calibration Kit (p/n: CET-715A-CK1)

The Calibration Kit contains the items necessary for common field and shop calibrations. It comes in a durable, hard plastic carrying case and includes a regulator, adapters, humidification chamber, brass fitting, hand tools and tubing. It does not include cylinders of gas. These must be ordered separately.



Calibration Kits and gases are available from the CETCI factory. Many gases, but not all are carried in inventory. Check with any CETCI authorized distributor for availability of specific gas types. **Gas cylinders cannot be shipped from Canada to other countries, including the USA.** For more information check out our website: <https://www.critical-environment.com/products/options-accessories/calibration-kit>

10 MAINTENANCE

The ESH-A Remote Sensor requires virtually no maintenance other than regular calibration.

The device should be monitored for possible damaging conditions.

- The sensor port should be kept free of dirt or soot build up.
- If in a damp location, source of water should be shielded from contacting the top of the device.

- If located in a working area, the front of the device should be kept clear.
- If painting is to be conducted in close proximity, the device needs to be protected from over spray and the sensor port should not receive paint fumes as these fumes may damage or reduce the life of the sensor.

11 TROUBLE SHOOTING

ESH-A won't power up.

Check the connections. Is the ESH-A properly connected to the controller or transmitter and is the controller or transmitter connected properly to a power supply?

Controller or transmitter shows a fault.

Check the ESH-A remote sensor. The signal will drop if the sensor fails.

After suggested warm up period, controller or transmitter shows readings that don't make sense.

Check to make sure the ESH-A that is connected to the transmitter or controller matches the serial number of said transmitter/controller. Each ESH-A is given the same serial number as the device it is being connected to. Make sure to connect the ESH-A to the controller or transmitter that has the same serial number or the system won't work properly. If that is not the cause, check voltage readings and do a calibration of the ESH-A as if it has a new / replacement sensor.

SAFER AIR EVERYWHERE.

www.critical-environment.com

ESH-A-20220309-B

Critical Environment Technologies™

Unit 145, 7391 Vantage Way, Delta, BC V4G 1M3 Canada

Tel: +1.604.940.8741 Toll Free: +1.877.940.8741

© 2021 All rights reserved. Data subject to change without notice.