

# INSTALLATION MANUAL



Rev. C | D 2025.11



**cGas Detector**  
Analog Transmitter | Digital Transmitter

[WWW.CETCI.COM](http://WWW.CETCI.COM)

## NEED MORE INFORMATION?

This is the **Installation Manual** for the cGas Detector models CGAS-A (analog transmitter) and CGAS-D (digital transmitter) models. If you would like to make sure you have the most current version or want to save it in pdf form, [click here](#) to open or download it from our website.

If you need more information, refer to the **cGas Detector Operation Manual**, which covers topics such as:

- Relay Operation
- Alarm Status, Fault Detection and Communication Failure Notifications
- Setting Channel Alarm Setpoints, Direction and Hysteresis
- Enable/Disable Internal Buzzer
- Enable/Disable Alarm Blink
- Enable/Disable Channels
- Delete Channels
- Replacing Plug & Play Smart Sensors
- Calibration
- Accessories
- Maintenance
- Troubleshooting

If you would like to view or download the **cGas Detector Operation Manual** from our website [click here](#)

**The most up-to-date version of the manual will always be on our website.**

---

# TABLE OF CONTENTS

<b>1 POLICIES</b> .....	<b>5</b>
1.1 Important Note .....	5
1.2 Warranty Policy .....	6
1.3 Service Policy .....	6
1.4 Copyrights .....	7
1.5 Disclaimer .....	7
1.6 Revisions .....	8
<b>2 SAFETY INFORMATION</b> .....	<b>9</b>
2.1 General Safety Warnings .....	9
2.2 Protection Against Electrical Risks .....	10
2.3 Protection Against Mechanical Risks .....	10
<b>3 INSTRUMENT SPECIFICATIONS</b> .....	<b>11</b>
3.1 General Description .....	11
3.2 Technical Specifications .....	12
3.3 Enclosure Dimensions .....	16
3.4 Exterior Enclosure .....	17
3.5 CGAS-A Interior System Layout .....	18
3.6 CGAS-D Interior System Layout .....	19
3.7 Single Channel Gas Sensor Options .....	20
3.8 Dual Channel Gas Sensor Options (CGAS-D only) .....	24
3.9 ESH-A-Remote Sensor Options .....	25
3.10 Calibration Extending Firmware (CEF) and Sensor Aging .....	25
<b>4 INSTALLATION</b> .....	<b>26</b>
4.1 Sensor Warm Up Time .....	26
4.2 Mounting the Transmitter .....	27
4.2.1 Wet Environment Considerations .....	27
4.2.2 EMI and RF Interference Considerations .....	28
4.2.3 Mounting Heights (sensor and application dependent) .....	29

---

<b>4.3 Enclosure Mounting Components</b> .....	<b>31</b>
4.3.1 Enclosure Base .....	32
4.3.2 Enclosure Bottom .....	32
<b>4.4 Wiring Connections</b> .....	<b>32</b>
4.4.1 Analog Wiring (CGAS-A only).....	33
4.4.2 Analog Wire Gauge vs Run Length (CGAS-A only) .....	34
4.4.3 Digital Wiring (CGAS-D only).....	35
4.4.4 Wiring the Relay (if installed) .....	38
4.4.5 ESH-A Remote Sensor Wiring Connection.....	40
<b>4.5 Power Draw Requirements</b> .....	<b>41</b>
<b>5 BASIC SYSTEM OPERATION</b> .....	<b>42</b>
5.1 General Info Screens.....	43
5.2 Navigating the Menu Structure .....	44
5.2.1 Accessing the Menu with Passcodes .....	44
5.3 Display Settings.....	45
5.3.1 Adjust Display Brightness .....	46
5.3.2 Display Configurations.....	46
5.4 Alarm Status, Fault Detection and Communication Failure Alerts ...	47
5.5 Change Analog Output (Milliamps - Voltage) (CGAS-A only).....	47
5.5.1 Set the Analog Output Type .....	48
5.5.2 Set the Analog Output Range .....	49
5.6 Change Units (°C or °F) of Temperature Readings.....	50
5.7 Temperature and/or Relative Humidity Offset .....	50
5.8 Test Functions.....	52
5.8.1 Test Analog Output (CGAS-A only) .....	52
5.8.2 Test Digital Output (CGAS-D only) .....	53
5.8.3 Test Relay and Buzzer (if installed) .....	54
<b>6 TROUBLE SHOOTING</b> .....	<b>55</b>

---

# 1 POLICIES

## 1.1 Important Note

Read and understand this manual prior to using this instrument. Carefully read the warranty policy, service policy, notices, disclaimers and revisions on the following pages.

This product must be installed by a qualified electrician or factory trained technician and according to instructions indicated in this manual. This instrument should be inspected and calibrated regularly by a qualified and trained technician.

This instrument has not been designed to be intrinsically safe. For your safety, **do not** use it in classified hazardous areas (explosion-rated environments).

**INSTRUMENT SERIAL NUMBER:**

---

**PURCHASE DATE:**

---

**PURCHASED FROM:**

---

## 1.2 Warranty Policy

Critical Environment Technologies Canada Inc. warrants the products we manufacture (excluding sensors, battery packs, batteries, pumps, and filters) to be free from defects in materials and workmanship for a period of two years from the date of purchase from our facility. Sensors are consumable items and once they leave our factory, we cannot reuse or resell them. As such, all sensor sales are final. Should the sensor itself be faulty, there is a one-year pro-rated warranty that would apply from the date of purchase from our facility.

The warranty status may be affected if the instrument has not been used and maintained as per the instructions in the manual or has been abused, damaged, or modified in any way. The product is only to be used for the purposes stated in the manual. Critical Environment Technologies is not liable for auxiliary interfaced equipment or consequential damage.

Prior to shipping equipment to CET, contact our office for an RMA #. All returned goods, regardless of reason, must be accompanied with an RMA number. Please read our Warranty and Returns Policy and follow our RMA Instructions and Form.

Due to ongoing research, development, and product testing, the manufacturer reserves the right to change specifications without notice. The information contained herein is based on data considered accurate. However, no warranty is expressed or implied regarding the accuracy of this data.

## 1.3 Service Policy

CET maintains an instrument service facility at the factory. Some CET distributors / agents may also have repair facilities; however, CET assumes no liability for service performed by anyone other than CET personnel.

Repairs are warranted for 90 days after date of shipment (sensors have individual warranties). Should your instrument require non-warranty repair, you

may contact the distributor from whom it was purchased or you may contact CET directly.

Prior to shipping equipment to CET, contact our office for an RMA #. All returned goods, regardless of reason, must be accompanied with an RMA number. Please read our Warranty and Returns Policy and follow our RMA Instructions and Form.

If the product is deemed repairable, for liability reasons, CET will perform all necessary repairs to restore the instrument to its full operating condition.

## 1.4 Copyrights

This manual is subject to copyright protection; all rights are reserved. Under international and domestic copyright laws, this manual may not be copied or translated, in whole or in part, in any manner or format, without the written permission of CET.

Modbus® is a registered trademark of Gould Inc. Corporation.

BACnet® is a registered trademark of American Society of Heating, Refrigeration and Air Conditioning (ASHRAE).

## 1.5 Disclaimer

Under no circumstances will CET be liable for any claims, losses or damages resulting from or arising out of the repair or modification of this equipment by a party other than CET service technicians, or by operation or use of the equipment other than in accordance with the printed instructions contained within this manual or if the equipment has been improperly maintained or subjected to neglect or accident. Any of the forgoing will void the warranty.

Under most local electrical codes, low voltage wires cannot be run within the same conduit as line voltage wires. It is CET policy that all wiring of our

products meet this requirement. It is CET policy that all wiring be within properly grounded (earth or safety) conduit.

## 1.6 Revisions

This manual was written and published by CET. The manufacturer makes no warranty or representation, expressed or implied including any warranty of merchantability or fitness for purpose, with respect to this manual.

All information contained in this manual is believed to be true and accurate at the time of printing. However, as part of its continuing efforts to improve its products and their documentation, the manufacturer reserves the right to make changes at any time without notice. In addition, due to improvements made to our products, there may be information in this manual that does not exist in the version of the product the user has. Should you detect any error or omission in this manual, or should you want to inquire regarding upgrading the device's firmware, please contact CET at the following address:

**Critical Environment Technologies Canada Inc.**  
**Unit 145 - 7391 Vantage Way,**  
**Delta, BC V4G 1M3 Canada**

**Toll Free: +1.877.940.8741**  
**Telephone: +1.604.940.8741**  
**Email: sales@cetci.com**  
**Website: www.critical-environment.com**

In no event will CET, its officers or employees be liable for any direct, special, incidental or consequential damages resulting from any defect in any manual, even if advised of the possibility of such damages.

**The most up-to-date version of the manual will always be on our website.**

## 2 SAFETY INFORMATION

The CGAS-A and CGAS-D comply with:

- CSA-C22.2 No. 205-12
- UL508 (Edition 18):2018
- EMC Directive 2014/30/EU
- EN 50270:2015, Type 1, EN61010
- FCC. This device complies with part 15 of the FCC Rules, Operation is subject to the following two conditions: (1) This device may not cause harmful interference, and (2) this device must accept any interference received, including interference that may cause undesired operation.
- CERTIFIED FOR ELECTRIC SHOCK & ELECTRICAL FIRE HAZARD ONLY. LA CERTIFICATION ACNOR COUVRE UNIQUEMENT LES RISQUES DE CHOC ELECTRIQUE ET D'INCENDIE D'ORIGINE ELECTRIQUE.
- CO and NO2 Sensors UL2075, 2nd Edition, Standard for Gas and Vapour Detectors and Sensors
- Listed by BTL (CGAS-D only)
- RoHS compliant circuit boards

### 2.1 General Safety Warnings

The cGas Detector is intended for indoor use, permanently mounted at a height that is appropriate for the type of gas being monitored. Refer to Section 4.2 *Mounting the Transmitter*. The cGas Detector should be protected from extreme weather conditions.

The cGas Detector requires no assembly and virtually no maintenance other than regular calibration of the internal and/or remote sensors. There are no serviceable elements other than the calibration instructions outlined in this manual. There are no replaceable components except the sensors.

It is important to ensure that excess water and/or dust is not somehow entering the enclosure and physically damaging the circuit board or internal components. Keep the gas detector, including the vents free of dirt, dust and

debris. If in a damp location, source of water should be shielded from entering the enclosure.

Check for physical damage, tampering, etc. on a consistent basis.

If painting is to be done in the same area, the gas detector needs to be protected from overspray and the sensor vent should be covered so as to not receive paint fumes. Paint fumes may damage and / or reduce the life of the sensor.

## **2.2 Protection Against Electrical Risks**

Disconnect all power before servicing. There may be multiple power sources. The power supply may have a building installed circuit breaker / switch that is suitably located and easy to access when servicing is required and should be labelled as cGas Detector supply (disconnecting power to the cGas Detector). Appropriate markings should be visible at the circuit breaker / switch that is supplying power to the cGas Detector.

This device may interfere with pacemakers. Modern pacemakers have built-in features to protect them from most types of interference produced by other electrical devices you might encounter in your daily routine. If you have a pacemaker, follow your healthcare provider's instructions about being around this type of equipment.

## **2.3 Protection Against Mechanical Risks**

The door of the enclosure can be removed if absolutely necessary to facilitate installation of the base, but it is not recommended on this model. Extreme care and caution must be exercised when removing the door to avoid damaging the hinges. The door should only be removed when absolutely required. Any damage occurring from the door removal procedure will not be covered under warranty.

If the unit is installed on a wall, open the enclosure fully, grasp the door,

---

keeping it open and being careful not to make contact with any of the internal components (circuit board). If the base is not mounted, grasp the base with your other hand. Tug on the door, pulling towards you making sure the door is still open and straight. **DO NOT TWIST.** The section of the hinges located on the base should "snap" apart from the part of the hinges located on the door.

After installation, place the door hinges over the installed base hinges, with the unit fully open and push towards the wall. The hinges should easily "snap" back into place.

The enclosure has one screw securing the door to the base for electrical safety and provides an opening to allow the user to apply a padlock or tie wrap if they desire the transmitter to be locked.

Be aware that the hinged door that could potentially pinch fingers and the sharp edges and/or jumper pins on the board could potentially prick or cut fingers if not handled carefully.

## 3 INSTRUMENT SPECIFICATIONS

### 3.1 General Description

The cGas Detector is a low maintenance gas monitoring device that offers flexible customization options with the purpose of meeting your specific application and budgetary requirements. It is ideal for monitoring toxic, combustible and refrigerant gases in non-hazardous (non-explosion rated) environments such as enclosed parking facilities, commercial HVAC, greenhouses, recreational facilities, refrigeration plants, manufacturing plants and other light industrial applications.

Both the analog and digital models are powered by 24 VDC or ground referenced AC, come with an LCD display, temperature compensation and thermal resetting fuse. Sensor replacement is easy with true Plug & Play smart

sensors that arrive pre-calibrated. The firmware and configuration can be upgraded in the field using the USB connection.

This manual covers the installation and wiring for both the CGAS-A and CGAS-D because they are very much the same. **The two main differences are:**

1. The **CGAS-A is an analog device** and can only have **one gas channel**. It sends an analog signal (4-20 mA, 0-10 v or 2-10 v) to a Controller or BAS/DDC.
2. The **CGAS-D is a digital device** and can have up to **two gas channels**. It communicates with the FCS System Controller using Modbus® RTU RS-485 or can be field configured to communicate with a BAS/DDC using Modbus® RTU RS-485 or BACnet® MS/TP RS-485. The cGas Detector is used to continuously monitor gas concentrations on one (or two) configured channel(s).

The sensors utilized in these devices are accurate enough to measure to Occupational Health & Safety (OHS) hazardous levels for toxic gases. These devices operate by diffusion.

## 3.2 Technical Specifications

### MECHANICAL

Enclosure	ABS / Polycarbonate, IP54 rating with splash guard installed. Copper coated interior to reduce RF interference.
Weight	400 g / 14 oz
Size	127 mm x 127 mm x 71 mm / 5.0 in x 5.0 in x 3.0 in
Conduit Entry Points	12.7 mm / 1/2 in diameter

---

Mounting Holes	4.47 mm / 0.175 in diameter maximum head diameter 8 mm / 0.32 in #8 or 4 mm screw
----------------	---

---

## USER INTERFACE

---

Display (standard)	2-line by 16-character graphic LCD, user configurable to suppress reading display and/or alter brightness
Display (Option -LT)	Optional OLED display for improved usability in low temperature applications, 2-line by 16-character
USB Port	Internal port for USB memory stick connection for in field configuration updates and firmware upgrades
Push Buttons	Initiate calibration and menu options with internal UP, DOWN and ENTER push buttons
Audible Alarm	Rated 90dB @ 10 cm / 4in, user enable/disable Comes standard with all 7 series electrochemical, IR refrigerant sensors, carbon dioxide sensor models. Can be added as Option -RBZ to other models.

---

## ELECTRICAL

---

Power Requirement	16 - 30 VDC, 3 W*, Class 2 12 - 27 VAC, 50-60 Hz, 3 VA, Class 2 24V recommended. Refer to Section 4.4 <i>Wiring Connections</i> <i>*dependent on sensor type. Refer to Sections 4.5 Power Draw Requirements</i>
-------------------	--

---

---

Analog Wiring	VDC (or ground referenced AC) 3-conductor 16 - 18 AWG shielded, stranded within conduit, VAC 4-conductor shielded 18 AWG stranded within conduit
Digital Wiring	VDC or VAC (ground referenced) 4-conductor shielded 18 - 22 AWG twisted, shielded, stranded within conduit network wiring (daisy-chain)
Fuses	Automatic resetting thermal

---

## INPUT/OUTPUT

---

Analog Output (CGAS-A models)	One Linear 4 - 20 mA output or jumper selectable 0-10 or 2-10 volts output
Digital Output Modbus® RTU (CGAS-D models)	Modbus® RTU (version 1.1b3) RS-485 Modbus® ID: 100* (default, configurable) Baud rate: 19,200 (default, configurable) Data bits: 8 Start bits: 1 Stop bits: 1 Parity: none (default, configurable)

---

BACnet® MS/TP Digital Output (CGAS-D models)	<p>BACnet® MS/TP (version 1 rev 14) RS-485 BACnet® MS/TP; ANSI/ASHRAE standard 135 BACnet® Communication protocol: 135-2012 Baud Rate: 76,800 (default, configurable) Base Address: 270 (default, configurable) MAC Address: 100* (default, configurable) Parity: none (default, configurable) Stop bits: 1 Data bits: 8 *100 is the default for transmitters only *101 increasing sequentially is the default for a system controller and transmitters</p>
Relay & Buzzer (Standard and Option -RBZ)	1 SPDT relay rated 30 volts, 2 amp max with internal buzzer rated 90 dB @ 10 cm / 4 in, enable/disable
Relay (Option -RLY)	1 SPDT relay rated 30 volts, 2 amp max
RH and Temperature (Option -RHT)	User selectable units (°C or °F), user selectable display or hide readings

## ENVIRONMENTAL

Operating Temperature	0°C to 40°C / 32°F to 104°F (standard) -40°C to 40°C / -40°F to 104°F (with Option -LT)
Operating Humidity	15 - 90% RH non-condensing
Pollution Degree	Degree 2
Altitude	below 2,000 m

## CERTIFICATION

Model: CGAS-D-XXX or CGAS-A-XXX  
S/N: CGASD1807B00010 or  
S/N: CGASA1807B00010

Rating: 16-30 VDC, 3W, Class 2  
12-27 VAC, 50-60 Hz, 3VA, Class 2



CERTIFIED FOR ELECTRIC SHOCK & ELECTRICAL FIRE HAZARD ONLY. LA CERTIFICATION ACNOR COUVRE UNIQUEMENT LES RISQUES DE CHOC ELECTRIQUE ET D'INCENDIE D'ORIGINE ELECTRIQUE.

Conforms to: CSA-C22.2 No. 205-12, UL508 (Edition 18):2018  
Conforms to: EMC Directive 2014/30/EU, EN 50270:2015, Type 1, EN61010  
Conforms to: FCC. This device complies with part 15 of the FCC Rules,  
Operation is subject to the following two conditions: (1) This device may not cause harmful interference, and (2) this device must accept any interference received, including interference that may cause undesired operation.

### 3.3 Enclosure Dimensions

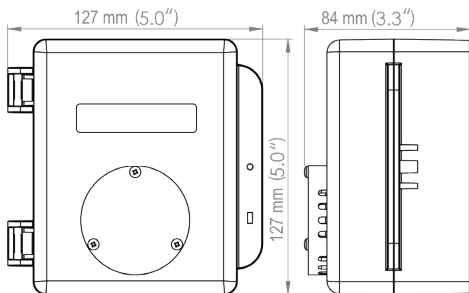

Above dimensions are shown with optional standard splash guard. Without splash guard, thickness is 71 mm / 3.0 in. The area required for enclosure door to be open 90 degrees is 178 mm / 7.0 in or 254 mm / 10.0 in for fully open. With the optional splash guard installed, the enclosure is IP54 rated.

**NOTE:** During calibration, the sensor response time will be slower with a splash guard installed.

**NOTE:** The standard splash guard (Option -S) is optional for protecting non sticky gas sensors in wash down applications. For sticky gas sensors such as Chlorine ( $\text{Cl}_2$ ), Chlorine Dioxide ( $\text{ClO}_2$ ), Hydrogen Chloride (HCL), Hydrogen Cyanide (HCN), Hydrogen Fluoride (HF), Ozone ( $\text{O}_3$ ) and Phosphine ( $\text{PH}_3$ ) order the sticky gas splash guard Option -SN or use the metal splash guard p/n: SCS-8000-WSG.

### 3.4 Exterior Enclosure



NUMBER	FEATURE	FUNCTION
1	Door Hinge	Secures door to base and allows easy opening and closing

<b>2</b>	Display	LCD display (standard display shown)
<b>3</b>	Sensor Opening	Allows gas diffusion into sensor
<b>4</b>	Door Screw	Secures door shut
<b>5</b>	Lock Slot	For security padlock or tie

### 3.5 CGAS-A Interior System Layout

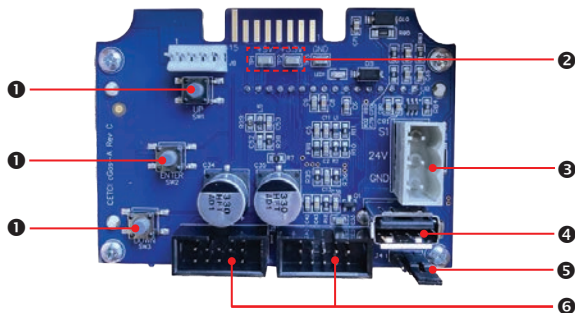

NUMBER	FEATURE	FUNCTION
<b>1</b>	Programming Buttons	Access menu options and program functions using buttons inside the enclosure. (Arrow up, Enter, Arrow down)

<b>2</b>	Test Points: TP1 & TP2	For measuring voltage output
<b>3</b>	TB1 Wiring Terminal	Pluggable terminal for Power & signal output
<b>4</b>	USB Connection	For firmware and configuration upgrades
<b>5</b>	J4 Output Jumper	For changing analog output from current to voltage
<b>6</b>	Sockets for smart sensor board	The gas smart sensor board plugs into the main board using these sockets

### 3.6 CGAS-D Interior System Layout

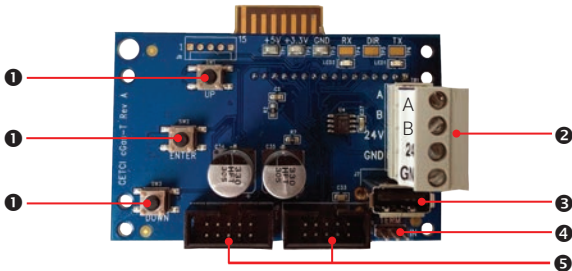

NUMBER	FEATURE	FUNCTION
<b>1</b>	Programming Buttons	Access menu options and program functions using buttons inside the enclosure. (Arrow up, Enter, Arrow down)

②	RS-485 Communication Terminals	Pluggable power and signal terminal for connection to controller and next transmitter.
③	USB Connection	For firmware and configuration upgrades
④	Termination Resistor	Network termination resistor. "IN" position includes 120 ohm resistor.
⑤	Sockets for sensors and Options boards	Sensor boards and Options boards plug into the main board using these sockets

### 3.7 Single Channel Gas Sensor Options

Internal 4 Series Electrochemical Sensors	Part Number		Range	Life Span
Carbon Monoxide (CO)	CGAS-D-CO <sup>1</sup>	CGAS-A-CO <sup>1</sup>	0 - 200 ppm	~3 yrs
Ethylene Oxide (C <sub>2</sub> H <sub>4</sub> O)	CGAS-D-EETO	CGAS-A-EETO	0 - 20 ppm	~2 yrs
Formaldehyde (CH <sub>2</sub> O)	CGAS-D-CH <sub>2</sub> O	CGAS-A-CH <sub>2</sub> O	0 - 5 ppm	~3 yrs
Hydrogen (H <sub>2</sub> )	CGAS-D-EH <sub>2</sub>	CGAS-A-EH <sub>2</sub>	0 - 2,000 ppm	~2 yrs
Hydrogen Sulphide (H <sub>2</sub> S)	CGAS-D-H <sub>2</sub> S	CGAS-A-H <sub>2</sub> S	0 - 50 ppm	~2 yrs
Nitric Oxide (NO)	CGAS-D-NO	CGAS-A-NO	0 - 100 ppm	~2 yrs
Nitrogen Dioxide (NO <sub>2</sub> )	CGAS-D-NO <sub>2</sub>	CGAS-A-NO <sub>2</sub>	0 - 10 ppm	~3 yrs
Oxygen (O <sub>2</sub> )	CGAS-D-O <sub>2</sub>	CGAS-A-O <sub>2</sub>	0 - 25% Vol	~3 yrs
Sulphur Dioxide (SO <sub>2</sub> )	CGAS-D-SO <sub>2</sub>	CGAS-A-SO <sub>2</sub>	0 - 20 ppm	~2 yrs

<b>Internal 7 Series Electrochemical Sensors</b>	<b>Part Number</b>		<b>Range</b>	<b>Life Span</b>
Ammonia (NH <sub>3</sub> )	CGAS-D-7NH3	CGAS-A-7NH3	0 - 500 ppm	~2 yrs
Carbon Monoxide (CO)	CGAS-D-7CO	CGAS-A-7CO	0 - 200 ppm	~5 yrs
Chlorine (Cl <sub>2</sub> )	CGAS-D-7CL2	CGAS-A-7CL2	0 - 5.0 ppm	~5 yrs
	CGAS-D-7CL2-10	CGAS-A-7CL2-10	0 - 10 ppm	~5 yrs
Hydrogen Cyanide (HCN)	CGAS-D-7HCN	CGAS-A-7HCN	0 - 30 ppm	~3 yrs
Hydrogen Fluoride (HF)	CGAS-D-7HF	CGAS-A-7HF	0 - 10 ppm	~2 yrs
Hydrogen Sulphide (H <sub>2</sub> S)	CGAS-D-7H2S	CGAS-A-7H2S	0 - 50 ppm	~5 yrs
Nitrogen Dioxide (NO <sub>2</sub> )	CGAS-D-7NO2	CGAS-A-7NO2	0 - 10 ppm	~5 yrs
Ozone (O <sub>3</sub> )	CGAS-D-7O3	CGAS-A-7O3	0 - 1 ppm	~2 yrs

<b>Internal Infrared Sensors</b>	<b>Part Number</b>		<b>Range</b>	<b>Life Span</b>
Carbon Dioxide (CO <sub>2</sub> )	CGAS-D-CO2-2K	CGAS-A-CO2-2K	0 - 2,000 ppm	~8 yrs
	CGAS-D-CO2-5K	CGAS-A-CO2-5K	0 - 5,000 ppm	
	CGAS-D-CO2-5%	CGAS-A-CO2-5%	0 - 5 %vol	
	CGAS-D-CO2-100%	CGAS-A-CO2-100%	0 - 100 %vol	

Refrigerants: R134A, R143A, R22, R32, R227ea, R404A, R407A, R407C, R407F, R410A, R417A, R422A, R422D, R427A, R434A, R438A, R442A, R448A, R449A, R450A, R452A, R453A, R454A, R454B, R507A, R513A, R514A, R1234YF, R1234ZE, R1233ZD				
	CGAS-D- IR134A CGAS-D- IR143A CGAS-D-IR22 CGAS-D-IR32 etc.	CGAS-A- IR134A CGAS-A- IR143A CGAS-A-IR22 CGAS-A-IR32 etc.	0 - 2,000 ppm	~5 yrs
Refrigerant R123	CGAS-D-IR123	CGAS-A-IR123	0 - 500 ppm	~5 yrs
Refrigerant RSF6	CGAS-D- IRSF6	CGAS-A-IRSF6	0 - 1,000 ppm	~5 yrs

Internal Solid State Sensors	Part Numbers		Range	Life Span
TVOC (Isobutylene)	CGAS-D- STVOC	CGAS-A- STVOC	0 - 500 ppm	~5 yrs

Internal Catalytic (Combustible) Sensors	Part Number		Range	Life Span
Butane (C <sub>4</sub> H <sub>10</sub> )	CGAS-D- CC4H10-100	CGAS-A- CC4H10-100	0 - 100% LEL	~5 yrs
Ethanol or Dimethyl Ether (C <sub>2</sub> H <sub>6</sub> O)	CGAS-D- CC2H6O-100	CGAS-A- CC2H6O-100	0 - 100% LEL	~5 yrs
Ethane (C <sub>2</sub> H <sub>6</sub> )	CGAS-D- CC2H6-100	CGAS-A- CC2H6-100	0 - 100% LEL	~5 yrs
Hydrogen (H <sub>2</sub> )	CGAS-D- CH2-100	CGAS-A- CH2-100	0 - 100% LEL	~5 yrs

Methane (CH <sub>4</sub> )	CGAS-D-CCH4-100	CGAS-A-CCH4-100	0 - 100% LEL	~5 yrs
Methanol (CH <sub>4</sub> O)	CGAS-D-CCH4O-100	CGAS-A-CCH4O-100	0 - 100% LEL	~5 yrs
Propane (C <sub>3</sub> H <sub>8</sub> )	CGAS-D-CC3H8-100	CGAS-A-CC3H8-100	0 - 100% LEL	~5 yrs

Internal PID Sensors	Part Number		Range	
TVOC	CGAS-D-SPL	CGAS-A-SPL	0 - 30 ppm	usage / application dependent
TVOC	CGAS-D-SPH	CGAS-A-SPH	0 - 300 ppm	

Internal RH & Temp Sensor	Part Number
Relative Humidity & Temp	CGAS-D-RHT

No Internal Sensor	Part Number
Add a remote ESH-A sensor	CGAS-D-R
Add a remote analog transmitter	CGAS-D-RT

### 3.8 Dual Channel Gas Sensor Options (CGAS-D only)

<b>Two Internal Electrochemical Sensors (4 Series)</b>	<b>Part Number</b>	<b>Range</b>	<b>Lifespan</b>
Carbon Monoxide (CO) and Nitrogen Dioxide (NO <sub>2</sub> )	CGAS-D-CO-NO2 <sup>1</sup>	0 - 200 ppm 0 - 10 ppm	~3 yrs ~3 yrs
Carbon Monoxide (CO) and Ethylene (C <sub>2</sub> H <sub>4</sub> )	CGAS-D-CO-C2H4 <sup>1</sup>	0 - 200 ppm	~3 yrs ~3 yrs
Carbon Monoxide (CO) and Hydrogen Sulphide (H <sub>2</sub> S)	CGAS-D-CO-H2S <sup>1</sup>	0 - 200 ppm 0 - 50 ppm	~3 yrs ~2 yrs
Carbon Monoxide (CO) and Oxygen (O <sub>2</sub> )	CGAS-D-CO-O2 <sup>1</sup>	0 - 200 ppm 0 - 25% vol	~3 yrs ~3 yrs
Carbon Monoxide (CO) and Nitric Oxide (NO)	CGAS-D-CO-NO <sup>1</sup>	0 - 200 ppm 0 - 100 ppm	~3 yrs ~3 yrs

<sup>1</sup>UL2075 Approved Carbon Monoxide sensor is available except for dual channel configurations that have Option -RHT.

<b>One Internal Sensor and One Remote Sensor</b>	<b>Part Number</b>
Choose internal sensor and add remote ESH-A sensor	CGAS-D-____-R add ESH-A
Choose internal sensor and add remote analog transmitter	CGAS-D-____-RT add ESH-A

### 3.9 ESH-A Remote Gas Sensor Options

Catalytic Sensors	Part Number	Range	Lifespan
Acetylene (C <sub>2</sub> H <sub>2</sub> )	ESH-A-CC2H2-100	0 - 100% LEL	~5 years
Hydrogen (H <sub>2</sub> )	ESH-A-CH2-100	0 - 100% LEL	~5 years
Methane (CH <sub>4</sub> )	ESH-A-CCH4-100	0 - 100% LEL	~5 years
Propane (C <sub>3</sub> H <sub>8</sub> )	ESH-A-CC3H8-100	0 - 100% LEL	~5 years

Infrared Sensors	Part Number	Range	Lifespan
Propane (C <sub>3</sub> H <sub>8</sub> )	ESH-A-JET	0 - 100% LEL	~8 years

PID Sensors	Part Number	Range	Lifespan
TVOCs	ESH-A-SPL	0 - 30 ppm	usage / application dependent
	ESH-A-SPH	0 - 300 ppm	

### 3.10 Calibration Extending Firmware (CEF) and Sensor Aging

The cGas Detector with integral electrochemical sensor(s) have been programmed with our CEF. This firmware takes into consideration the aging of the electrochemical CO and NO<sub>2</sub> sensors so that less frequent calibrations are required in less-critical applications such as parking garages. The system tracks the age of the sensor and automatically compensates for the reduced output of the sensor as it ages.

## 4 INSTALLATION

### 4.1 Sensor Warm-Up Time

Sensors go through a burn-in period at our factory prior to shipping, so they are ready for operation upon arrival after a warm-up period. The length of warm-up time will depend on the type of gas, sensor type, environment, and other factors. As a general rule, CET suggests that upon power-up, all sensors be left to warm up for a minimum of 24 hours to stabilize before they can be considered to provide accurate gas readings.

#### Exceptions:

- CO and NO<sub>2</sub> sensors typically stabilize quickly and, under normal operating temperatures, can become operational within approximately 5 minutes of power-up.
- After installing a cGas Detector with an Oxygen sensor, leave it to warm up for 2 to 6 hours before looking at the readings. If after a minimum of 24 hours the gas reading is not 20.9%, you should do a span calibration.
- Refrigerant sensors should be operational in 1 minute and up to full specification in 1 hour. Long power-off periods may require extended stabilization (up to 24 hours).
- If the cGas Detector is being installed in an environment that is greater than +/- 10 degrees from ambient (22°C (71.6°F)) then a calibration should be done in that same temperature range.

Silicone, lead, paint fumes, solvents and chlorinated hydrocarbon vapours can poison catalytic sensors (ie. C<sub>3</sub>H<sub>8</sub>, CH<sub>4</sub>). High humidity, condensation, dust and dirt can compromise infrared sensor performance.

A bump test will help you determine if a sensor requires calibration. If the sensor still does not respond as it should after calibration, it probably requires replacing.

All sensors are calibrated in the factory and should not require calibration at the time of a routine installation or replacement.

## 4.2 Mounting the Transmitter

The cGas Detector should be installed vertically and upright on a flat surface like a wall or a column. Secure the transmitter using the the four 4.4 mm / 0.175 in diameter mounting holes provided to maintain water tight status.

**Care should be taken to ensure that the face of the cGas Detector is not obstructed in order to maximize the sensor's exposure to the environment being monitored. Do not mount the transmitter upside down, sideways or flat on the floor or other surface.**

Two ½ in / 12.7 mm conduit entry points are provided in the enclosure. Both are located in the enclosure base. One in the rear of the base and one on the bottom edge of the base. Refer to *Section 4.3 Enclosure Mounting Components*.

The clearance from the PCA to the base enclosure is 12.7 mm / ½ in. **Do not use a conduit connector that has more than 12.7 mm (½ in) of thread length.**

**NOTE:** When mounting the enclosure, allow enough room to allow the end user to open the door fully to access the internal adjustments.

### 4.2.1 Wet Environment Considerations

If the cGas Detector is to be installed in a potential hose-down application or any application whereby liquid could be directed towards the sensor opening, the cGas Detector should be ordered with an optional attached splash guard (factory installed).

**If used in a wet or wash down application, the conduit hub entering the cGas Detector enclosure must be liquid tight type.** Water damage is not covered under warranty. Any physical damage to the transmitter or interior components

that occurs from the installer drilling the installation holes will not be covered under warranty.

#### **4.2.2 EMI and RF Interference Considerations**

All electronic devices are susceptible to EMI (Electromagnetic Interference) and RFI (Radio Frequency Interference). Our detectors have been designed to reduce the effects of these interferences and we meet CSA FCC and CE requirements for these type of devices. However there are still circumstances and levels of interference that may cause our equipment to respond to these interferences and cause them to react as if there has been gas detected.

There are some installation procedures that will reduce the likelihood of getting faulty readings:

1. Locate the detectors and controllers out of the way from normal foot traffic and high energy equipment.
2. Confirm the devices are properly grounded using conduit and shielded cabling.
3. Inform operators and technical staff working in the surrounding area to be aware of these possible conditions and that two way radios, cell phones and other electrical equipment may interfere with the response of the gas detectors.

#### **4.2.3 Mounting Heights (sensor and application dependent)**

The gas detector needs to be mounted where it will best detect the target gas. Some applications may require some adjustments, but generally speaking, the mounting height will depend on the density of the target gas relative to air.

- Heavier than air gases fall towards the floor and collect in low lying areas requiring the gas detector to be mounted 6 in / 15 cm from the floor.
- Lighter than air gases float upwards and collect at the ceiling. Lighter

than air sensors should be placed on or near the ceiling.

- Gases that have a density close to that of air should have the sensors installed in the breathing zone. The breathing zone refers to the area 1.2 - 1.8 m / 4 - 6 ft from the floor, where most human breathing takes place. This is a good default location for sensors, as many gases are often well dispersed in air.

### Typical Mounting Height by Gas:

GAS TYPE	MOUNTING HEIGHT	COVERAGE (ft <sup>2</sup> )	COVERAGE (m <sup>2</sup> )
Ammonia (NH <sub>3</sub> )	on or near the ceiling	3000	279
Butane (C <sub>4</sub> H <sub>10</sub> ) (combustible)	6 in (15 cm) from floor	3000	279
Carbon Dioxide (CO <sub>2</sub> )	breathing zone	3000	279
Carbon Monoxide (CO)	breathing zone	5000 - 7500	465 - 697
Carbon Monoxide (CO) in parking garages	breathing zone	50 ft radius	15 m radius
Chlorine (Cl <sub>2</sub> )	6 in (15 cm) from floor	3000	279
Ethane (C <sub>2</sub> H <sub>6</sub> ) (combustible)	6 in (15 cm) from floor	3000	279
Propane (C <sub>3</sub> H <sub>8</sub> ) (combustible)	6 in (15 cm) from floor	3000	279
Methane (CH <sub>4</sub> ) (combustible)	on or near the ceiling	5000	465

Hydrogen (H <sub>2</sub> ) (combustible)	on or near the ceiling	5000	465
Ethanol (C <sub>2</sub> H <sub>6</sub> O) (alcohol)	6 in (15 cm) from floor	3000	279
Methanol (CH <sub>4</sub> O) (alcohol)	6 in (15 cm) from floor	3000	279
Hydrogen (H <sub>2</sub> ) (electrochemical)	application dependent	3000	279
Ethylene (C <sub>2</sub> H <sub>4</sub> )	breathing zone	5000	465
Fluorine (F <sub>2</sub> )	6 in (15 cm) from floor	3000	279
Formaldehyde (CH <sub>2</sub> O)	breathing zone	3000	279
Hydrogen Chloride (HCl)	12 in (30 cm) from floor	3000	279
Hydrogen Cyanide (HCN)	12 in (30 cm) from floor	3000	279
Hydrogen Sulphide (H <sub>2</sub> S)	6 in (15 cm) from floor	3000	279
Nitric Oxide (NO)	breathing zone	5000	465
Nitrogen Dioxide (NO <sub>2</sub> )	breathing zone	5000	465
Nitrogen Dioxide (NO <sub>2</sub> ) in parking garages	breathing zone	50 ft radius	15 m radius
Oxygen (O <sub>2</sub> )	breathing zone	5000	465

Ozone (O <sub>3</sub> )	6 in (15 cm) from floor	3000	279
Phosphine (PH <sub>3</sub> )	breathing zone	3000	279
Silane (SiH <sub>4</sub> )	breathing zone	3000	279
Sulphur Dioxide (SO <sub>2</sub> )	6 in (15 cm) from floor	3000	279
All freon refrigerants	12 in (30 cm) from floor	3000	279
TVOCs	target gas dependent	3000	279

## 4.3 Enclosure Mounting Components

### 4.3.1 Enclosure Base

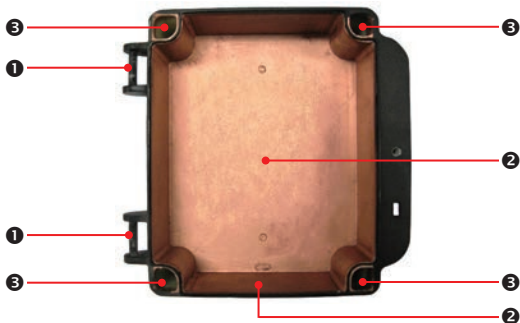

NUMBER	FEATURE
①	Door Hinge
②	Conduit Entry Points 12.7 mm / 1/2 in diameter
③	Mounting Holes 4.47 mm / 0.175 in diameter maximum head diameter 8 mm / 0.32 in, #8 or 4 mm screw

#### 4.3.2 Enclosure Bottom



NUMBER	FEATURE
①	Door Hinge
②	Conduit Entry Points 12.7 mm / 1/2 in diameter

#### 4.4 Wiring Connections

The cGas Detector transmitter is a low voltage powered device. Any application of operating voltages higher than indicated in the specification may result in damage. Double check wiring connections prior to powering the transmitter. Damage from incorrect wiring connections or from too much voltage applied is not covered under warranty.

The cGas Detector Transmitter supports both 24 VAC and 24 VDC power. During installation, it's critical to maintain consistent grounding—not for power delivery, but for reliable communication. Inconsistent grounds can cause signal variations between devices, leading to data corruption and system malfunctions.

In 24 VAC systems, using multiple small VA transformers without properly tying their grounds together often results in inconsistent grounding. Since communication chips reference their transmitter's ground, mismatched grounds create differing signal references and corrupt data.

With 24 VDC systems, installers typically connect all grounds together, ensuring uniform grounding and reducing communication issues. Using a 4-conductor cable with a dedicated ground wire further improves reliability.

For large jobs (30+ cGas transmitters) that are not connected to a CET Controller and Remote Power Supplies, we recommend using 4 conductor wiring and 24 VDC power supplies to provide a consistent ground.

**NOTE: WARRANTY VOID IF SOLID-CORE WIRE IS USED AT THE WIRING TERMINAL STRIP.**

When using solid core wiring for distribution (in the conduit), use stranded wire pigtails 14 - 18 AWG within the enclosure to connect to the circuit board. The rigidity of solid-core wire can pull a soldered terminal strip completely off a circuit board and this will not be covered under warranty.

#### **4.4.1 Analog Wiring (CGAS-A only)**

All wiring should be run in EMT (or better) conduit properly earth grounded. Signal output and supply should be in shielded cable. The cable shield should be connected to earth ground at the controller/power supply that is providing power for the cGas.

If the cGas Detector is connected to an FCS, the supply voltage will be supplied by the FCS and if required, additional power can be supplied by RPS-24VDC Remote Power Supply devices. In an analog configuration, a dedicated 4-20 mA signal wire is connected to each transmitter and only the ground and power wires are daisy chained.

### CGAS-A Connected to an FCS Controller (3-wire VDC)

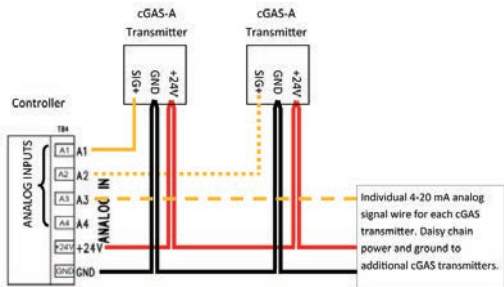

If the cGas Detector is being connected to a BAS, DDC or other control panel then either a 24 VDC power supply or 24 VAC Class 2 or better transformer need to be used.

In all cases the voltage supply to the cGas Detector should never drop below 16 VDC or 12 VAC.

#### 4.4.2 Analog Wire Gauge vs Run Length (CGAS-A only)

The table below shows the **maximum cable length between the cGas Detector and the Controller** for normal installations (a separate signal line from the controller for each cGas Detector is required).

SUPPLY VOLTAGE	MAXIMUM LOAD (Wire + Termination Resistor) (ohms)	WIRE GAUGE (AWG)	MAXIMUM CABLE LENGTH (feet)
24 VDC	592 (assume a 500 $\Omega$ termination resistor)	18	7,100
		16	10,700
		14	20,000
16 VDC	216 (assume a 200 $\Omega$ termination resistor)	18	1,200
		16	1,800
		14	3,500
24 VAC	1,060 (assume a 500 $\Omega$ termination resistor)	18	43,200
		16	65,500
		14	100,000
12 VAC	316 (assume a 200 $\Omega$ termination resistor)	18	8,900
		16	13,583
		14	25,000

**NOTE:** The termination resistor could be as high as 500  $\Omega$  (10-volt measurement at 20 mA). A poor quality 24 VAC transformer might supply as little as 14 volts at low line conditions.

#### 4.4.3 Digital Wiring (CGAS-D only)

All wiring should be run in EMT (or better) conduit properly earth grounded. All communications (network) wiring must be in shielded cabling. Wire shielding must be connected together at each device and taped off so it cannot cause a short on the circuit board when the door is closed. The wiring shield should

be connected to ground only at the controller, have a contiguous connection throughout the network and be left taped and floating at the last device in the network.

	<b>Power</b>	<b>Modbus® Communication</b>	<b>BACnet® Communication</b>
<b>Connections</b>	Ground + Power	A + B	A + B + Ground/ ref
<b>Gauge</b>	16 - 18 AWG	18 - 22 AWG	18 - 22 AWG
<b>Characteristics</b>	Shielded, Stranded	Capacitance $\leq 100$ pF/m ( $\leq 30$ pF/ft) Impedance 100 - 130 ohms Twisted, Shielded, Stranded	
<b>Recommended Products</b>	Cerco BAI09 (16 AWG) Cerco 7570 (18 AWG) Belden 9952 (16 AWG)	Belden 3074F (18 AWG) Belden 3105A (22 AWG) AlphaWire 6453 (22 AWG)	Belden 3106A (22 AWG) AlphaWire 6454 (3x22 AWG)

To ensure robust data communications, a daisy chain wiring configuration must be used. No tee taps. No star configurations. This means, four wires run from one end of the digital network to the other, through the same connections along the entire run. From one digital device to the next digital device, A goes to A; B goes to B; GND goes to GND; 24V goes to 24V. Do not mix up the individual wires or the two groups of four wires.

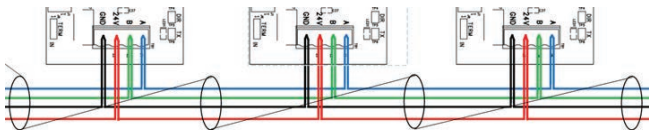

An end of line jumper must be installed at both ends of the digital network. To terminate, you must place a 120 ohm resistor on the IN (or sometimes labelled EN) termination jumper position ON the TERM jumper on the FIRST DIGITAL DEVICE (which might not be the Controller) and the LAST DIGITAL DEVICE in the wire run. The termination resistor jumper on all other digital devices in the network should be in the disabled position. Every CET digital device has a termination resistor jumper. The factory default setting of the termination resistor on all digital devices disabled.

### Wiring Example: 4-Wire VAC

If the cGas Detector is being connected to a BAS, DDC or other control panel then either a 24 VDC power supply or 24 VAC Class 2 or better transformer needs to be used.

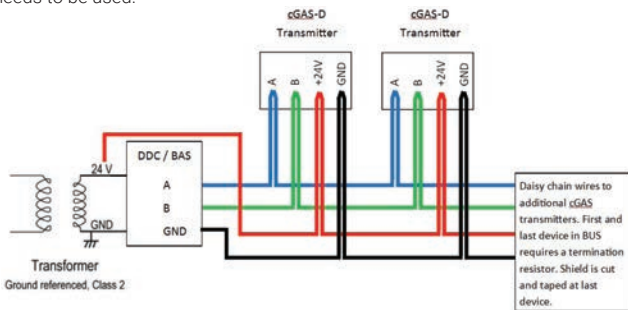

### Wiring Example: 4-Wire VDC

If the cGas Detector is being connected to an FCS the supply voltage will be supplied by the FCS and any additional power requirements of the system will be supplied by RPS-24VDC Remote Power Supply devices.

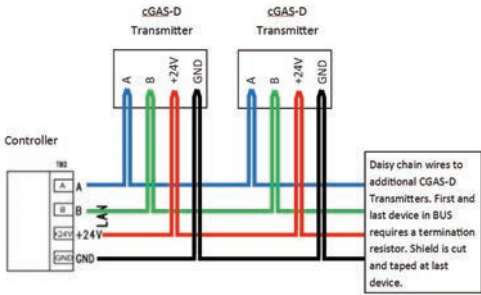

**NOTE:** When wiring transmitters or the FCS WAN to a third party controller / control panel / BAS / DDC and there is a discrepancy between CET's recommended wire gauge and the third party specifications, we recommend following the recommendations of the third party.

In large system applications, an LNK-XT Network Extender can be used to boost a decreasing signal strength. One LNK-XT extends the network length up to an additional 914 m (3,000 ft). It is recommended that an LNK-XT be installed when a drop in signal strength is detected. The addition of an RPS-24VDC Remote Power Supply may be required.

#### 4.4.4 Wiring the Relay (if installed)

The cGas does not provide any power from the relay terminal.

The relay is single pole, double throw thereby providing one set of usable dry contacts for the relay. A dry contact relay operates like a switch to simply activate (switch on) or de-activate (switch off) equipment to be controlled, such as a remote horn and fan starters.

If the relay and buzzer are installed, the SPDT dry contact relay is rated 30 volts, 2 amps max and the internal buzzer is rated 90dB @ 10 cm / 4in.

cGas sensors that come standard with relay and buzzer:

- 7 series electrochemical toxic and sticky gas sensors
- IR refrigerant gas sensors

cGas models that **do not** come standard with a relay and buzzer. If a relay and buzzer is required, you must add **Option RBZ**:

- 4 series electrochemical toxic gas sensors
- Combustible (catalytic) gas sensors
- CO2 gas sensors
- PID TVOC gas sensors

If only a relay is needed, **Option RLY** can be added to a single channel model with a:

- 4 series electrochemical toxic gas sensor
- Combustible (catalytic) gas sensor
- PID TVOC gas sensor

**NOTE:** 4 series sticky gas sensor **cannot** have a relay and buzzer.

The cGas Detector is designed to be fail-safe. Equipment to be controlled by the relay should be wired to the "NC" (Normally closed) and "COM" (Common) terminals. With this wiring, the connection will be open under normal, low gas concentration conditions. When the gas concentration rises to the configured alarm point or if there is a power failure, the relay NC connection will close to the relay COM. The relay coils are normally energized in a non-alarm state

for failsafe operation. Refer to *cGas Detector Operation Manual* for more information on the operation of the relay.

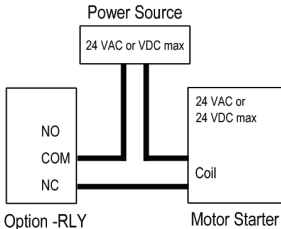

#### 4.4.5 ESH-A Remote Sensor Wiring Connection

Each ESH-A is given the same serial number as the device it is being connected to. Make sure to connect the ESH-A to the CGAS-D that has the same serial number or the cGas factory calibration will be void.

Four-conductor, 16 AWG stranded shielded cable is recommended for the ESH-A remote sensor wiring. This wiring should be run in a conduit, separate from the signal output, and should not exceed 15 m (50 ft). The voltage at the remote sensor (Red V+ to Black GND) should not be below 4.5 volts. If this voltage is not met after installation, the wrong gauge wire may have been used or the wiring run is too long.

#### Wiring Example: ESH-A Remote Sensor

Note: The maximum length of wire between the ESH-A Remote Sensor and the cGas Detector should not exceed 15 m (50 ft).

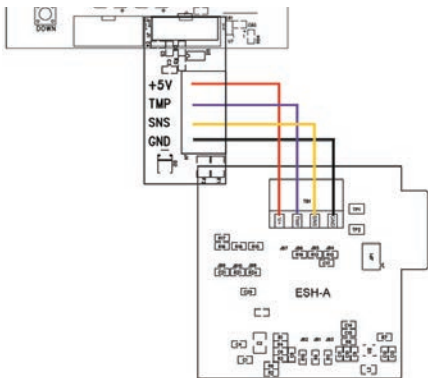

## 4.5 Power Draw Requirements

CGAS MODEL	PEAK POWER CONSUMPTION
CGAS-A-CO	1.68 watts
CGAS-D-CO	1.2 watts
CGAS-A-CO2	1.8 watts
CGAS-D-CO2	1.5 watts
CGAS-A-NO2	1.68 watts
CGAS-D-NO2	1.2 watts
CGAS-A-H2S	1.68 watts
CGAS-D-H2S	1.2 watts

---

CGAS-A-R + ESH-A	3 watts
CGAS-D-R + ESH-A	2.5 watts
CGAS-A with internal catalytic sensor	3 watts
CGAS-D with internal catalytic sensor	1.5 watts
CGAS-A-IR refrigerant sensor	2.3 watts
CGAS-D-IR refrigerant sensor	1.8 watts
CGAS-D-CO-NO2	1.3 watts
CGAS-D-CO-H2S	1.3 watts

---

**Add to Peak Power Consumption if installed:**

---

CGAS Buzzer + Relay (Option -RBZ)	0.7 watts
CGAS Relay (Option -RLY)	0.15 watts

---

## 5 BASIC SYSTEM OPERATION

The cGas Detector is a low maintenance, continuous gas monitoring device that offers flexible customization options with the purpose of meeting your specific application and budgetary requirements. It is ideal for monitoring toxic, combustible and refrigerant gases in non-hazardous (non-explosion rated) environments such as enclosed parking facilities, commercial HVAC, greenhouses, recreational facilities, refrigeration plants, manufacturing plants and other light industrial applications. It can be connected to a controller (FCS, DCC or SCC), a control panel or a BAS / BMS / DDC system. If the relay and buzzer is installed, the cGas Detector can operate as standalone device.

**NOTE:** For functions that do not appear in this section, refer to the *cGAS Detector Operation Manual*.

Upon application of power to a cGas Detector shipped from the factory, the LCD display will turn on and rotate through several info screens that differ depending on the configuration of the transmitter. The warm-up period takes between 2 and 5 minutes depending on the gas sensors type.

The cGas Detector will be visible on the controller / BAS / DDC system during the warm-up countdown and will output a default value to prevent alarms. The accurate reading will show up when the unit has finished the warm-up period and the sensor(s) has stabilized.

All alarms will be disabled during the system warm-up period. After the warm-up period, the system may exhibit gas alarm condition(s) if one or both of the sensors has not completely stabilized during the warm up period. This is normal and the length of time the gas alarms exist is dependent upon the length of time since the unit was last powered up, and the state of the environment it is installed in. Refer to *Section 4.1 Sensor Warm Up time* for more information.

**Upon power-up, all sensors\* should be left to warm up for 24 hours prior to considering the gas readings to be accurate.**

\*except, Ammonia, which should be left to warm up for 48 hours.

**NOTE:** All sensors are calibrated in the factory prior to shipping and should not require calibration at the time of a routine installation or replacement.

## 5.1 General Info Screens

Pressing the UP or DOWN buttons during normal operation allows you to scroll

through a series of information screens showing the model name and firmware version; the gas type and AD counts; the communications ID number, gas type and gas level; and temperature and relative humidity (if option -RHT is installed).

## 5.2 Navigating the Menu Structure

The three programming push-buttons inside the enclosure are used to navigate through the cGas Detector menu structure. Refer to Sections 3.5 & 3.6 *Interior System Layout* for location photo.

### Push-Button Operation

The UP and DOWN buttons are used to scroll through screens, menus or setting choices depending on the screen displayed. The ENTER button is used to initiate menu operation, choose a setting or confirm a choice depending on the screen displayed.

### Numeric Entry

On any screen where a number will be directly entered (such as passcode entry) the following operation applies. Numbers are entered left to right 1 digit at a time with an underline/cursor indicating the digit currently being edited. Use the UP/DOWN buttons to change the currently selected digit. Press ENTER to move to the next digit. Except for where you enter the passcode, all other settings requiring numeric entry will be followed with a Yes/No confirmation once the entire number is entered in case any mistakes were made.

#### 5.2.1 Accessing the Menu with Passcodes

From any normal operation screen press ENTER to bring up the passcode entry screen. Enter one of the following passcodes using the Numeric Entry method described in the previous section.

- Service Passcode: 2020
- Admin Passcode: 2019

**NOTE:** Service Passcode 2020 is ideal for service technicians or anyone who only needs quick access to Testing and Calibration.

The CGAS menu structure is broken into the following 3 levels:

- Top Menu
- Parent Menu
- Menu Items

The Top Menu will allow you to choose a Parent Menu that lists specific settings and operations that you want to access. For example, Testing, Calibration, Alarm, Relays, etc. Navigate to the desired Parent Menu and press ENTER.

Once in a Parent Menu a list of available Menu Items are shown. Each Menu Item will have a title on the top line and the current setting on the bottom line. Use the UP/DOWN buttons to scroll through the available Menu Items. The currently displayed items will depend on your device's configuration as well as the currently selected channel or relay.

Pressing ENTER on any Menu Item screen will add a > to the bottom line. This indicates that you are now able to change the setting. Use the UP/DOWN buttons to change the value and ENTER to select. Once a selection is made the > will disappear indicating that you are back in the Parent Menu.

**NOTE:** After 5 minutes of inactivity in any of the menus, the display will return to the normal operation.

## 5.3 Display Settings

The LCD display can display up to 2-lines of 16-characters. After warm-up and upon normal operation, the display will show the current gas level reading for each channel that it has been configured. Pressing the UP or DOWN buttons allows you to scroll through a series of information screens showing the model name and firmware version; the gas type and AD counts; the communications ID number, gas type and gas level; and temperature and relative humidity (if option -RHT is installed).

### 5.3.1 Adjust Display Brightness

The brightness of the display can be changed in increments of 10. The factory default is full brightness (100). You cannot enter a number higher than 100. Entering a value of 0 turns the backlight off completely but with ambient light the text can still be read on the display.

Enter passcode 2019 and press the ENTER button.

Enter Passcode 2019
------------------------

Navigate to the Display parent menu and then to the Brightness menu item.

Choose Menu >Display	Brightness 100
-------------------------	-------------------

Enter the numeric value as desired and press ENTER.

Brightness >050	Brightness 50
--------------------	------------------

### 5.3.2 Display Configurations

The factory default display setting is Normal, which displays the gas type, gas reading and gas units for CH1. The information can be reduced to just the gas type by changing the setting to the minimal mode display.

Normal	Minimal
CO2                      536 PPM	CO2

Enter passcode 2019 and press the ENTER button.

Enter Passcode 2019
------------------------

Navigate to the Display parent menu and then to the Display Type menu item and press ENTER.

Choose Menu >Display	Display Type Normal
-------------------------	------------------------

Choose the preferred display setting and press ENTER.

Display Type >Minimal	Display Type Minimal
--------------------------	-------------------------

## 5.4 Alarm Status, Fault Detection and Communication Failure Notifications

If a channel is in alarm, the following letters will be displayed at the end of the line for that channel.

- low for low alarm
- mid for mid alarm
- high for High alarm

CO	0 PPM
NO2	0.7 low

CO	0 PPM
NO2	1.0 mid

CO	0 PPM
NO2	1.5 high

The cGas Detector has built in fault detection, and in the event of a problem with the measurement circuitry the transmitter will indicate a fault condition on the display. Normal operation will resume once the fault condition has been corrected.

**NOTE:** If a question mark ? is displayed, the system is reading slightly negative but not enough to adversely affect the alarm functionality; a re-zeroing is recommended.

If there is a communication failure between the cGas Detector and the controller or BAS, the screen will display COMM at the end of the line.

CO	0 COMM
NO2	0 COMM

For a list of Fault Codes, refer to *Section 6 Troubleshooting*.

## 5.5 Change Analog Output (Milliamps - Voltage)

The factory default analog output for the cGas detector is 4-20 mA. The analog output can be changed to voltage in the field.

**Begin by moving the Output Jumper on jumper bank J4.** It is located on the

bottom right corner of the main circuit board from I to V. Refer to Section 3.5 *Interior System Layout* for location photo.

The black area in the following image represents the positions of the jumper for current and voltage.

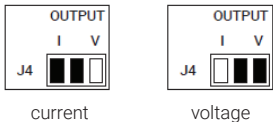

### 5.5.1 Set the Analog Output Type

The factory default analog output type is current. The analog output type can be changed from current to voltage and vice versa in the field.

**NOTE:** Make sure the jumper is in the correct position for the output you are choosing.

Enter passcode 2019 and press the ENTER button.

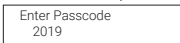

Navigate to the Analog Outputs parent menu and press ENTER.

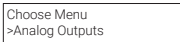

Navigate to the Set AO Type menu item and change the Current (mA) to Voltage (V). Press ENTER.

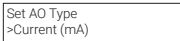

If you want 0-10 volt output, you are finished. If you want 2-10 volt output or other values you need to set the analog output range. Refer to Section 5.5.2 *Set the Analog Output Range*.

### 5.5.2 Set the Analog Output Range

The factory default analog output for the cGas detector is 4-20 mA. The default voltage output value is 0-10 volts. The output range can be changed, for example to 0-20 mA or 2-10 volts. The maximum level of output for voltage is 10 volts and the maximum for current output is 23 mA.

Enter passcode 2019 and press the ENTER button.

Enter Passcode 2019
------------------------

Navigate to the Analog Outputs parent menu and press ENTER.

Choose Menu >Analog Outputs
--------------------------------

Navigate to Set AO Zero menu item. Press ENTER and enter the value as required.

Set AO Zero >0
-------------------

Set AO Zero >02.0 V
------------------------

Press ENTER to confirm the value is correct.

Confirm?	N
>02.0 V	>Y

Navigate to Set AO Range menu item. Press ENTER and enter the value as required.

Set AO Range >10
---------------------

Set AO Range >08.0 V
-------------------------

Press ENTER to confirm the value is correct.

Confirm?	N
>08.0 V	>Y
Set AO Range	8.0 V

The Set AO Zero value is the current or voltage at which the device signals no (zero) gas. The Set AO Range value is the current or voltage at which the device signals maximum gas.

## 5.6 Change Units (°C or °F) of Temperature Readings

**NOTE:** This menu item only applies if the cGas Detector has the -RHT option installed.

You can change the factory configured temperature unit type from Celsius to Fahrenheit (or vice versa) very easily.

Enter passcode 2019 and press ENTER.

Enter Passcode  
2019

Navigate to the Calibration parent menu and then to the Selected Channel menu item.

Choose Menu  
>Calibration

Make sure Temperature is selected and navigate to the Temperature Unit menu item and press ENTER.

Selected Channel  
CO2

Selected Channel  
>Temperature

Change the value to the desired unit type and press ENTER.

Temperature Unit  
>Celsius

Temperature Unit  
Fahrenheit

**NOTE:** All settings for the Temperature channel will automatically update to the equivalent value in the chosen unit. For example: an alarm point of 0°C will change to 32°F.

## 5.7 Temperature and / or Relative Humidity Offset

**NOTE:** This menu item only applies if the cGas Detector has the -RHT option installed.

**NOTE:** Depending on the configuration, the device will show the temperature in either Celsius or Fahrenheit. The units can be changed at any time, refer to

### Section 5.6 Change Units (°C or °F) of Temperature Readings.

The temperature and relative humidity sensor is calibrated prior to shipping. If the readings on the cGas Detector are higher or lower than another device measuring the ambient temperature or relative humidity, you can adjust the reading by setting an offset value so the reading is more accurate. The Temperature offset value is a number of degrees in either direction of 0 and the Humidity offset value is a percentage between 0 or 100.

Enter passcode 2019 and press ENTER.

Enter Passcode 2019
------------------------

Navigate to the Calibration parent menu and then to the Selected Channel menu item.

Choose Menu >Calibration
-----------------------------

Make sure Temperature (or Humidity) is selected and navigate to the Temperature Adj (or Humidity Adj) menu item and press ENTER.

Selected Channel CO2
-------------------------

Selected Channel >Temperature
----------------------------------

Selected Channel >Humidity
-------------------------------

Enter the desired offset value and press ENTER.

Temperature Adj >-4.0 degC
-------------------------------

Humidity Adj >+02 %RH
--------------------------

Press ENTER to confirm the value is correct.

Confirm?	N
>-4.0 degC	>Y

Confirm?	N
>+2 %RH	>Y

## 5.8 Test Functions

### 5.8.1 Test Analog Output (CGAS-A only)

Testing the analog output allows you to determine if the installation was successful. The test forces the cGas Detector to output a predetermined signal to the controller or DDC/BAS to test that the correct signal is being transmitted and the controller responds as configured (ie. if analog output is configured for VFD control, the fans operate as expected).

**NOTE:** The factory configured default entry is 4 mA. If the analog output type has been changed to voltage, the default entry is 0.0 volts.

**NOTE:** The minimum and maximum output values are 0 to 30 mA (or 0 to 10 volts).

Enter passcode 2020 and press ENTER.

Enter Passcode 2020
------------------------

Navigate to the Testing parent menu and then to the Test AO menu item and press ENTER.

Choose Menu >Testing
-------------------------

Enter the desired value and press ENTER.

Test AO 4.0 mA
-------------------

Test AO >14.0 mA
---------------------

Press ENTER to confirm the value is correct.

Confirm? >14.0 mA	N >Y
----------------------	---------

Test AO 14.0 mA
--------------------

The test will start as soon as you press ENTER to confirm. To stop the test, press the UP or DOWN button. To test another analog output value repeat the process by pressing ENTER.

### 5.8.2 Test Digital Output (CGAS-D only)

For each gas channel, you can manually enter a gas reading value of your choice (within the range of the sensor) that will be sent over the digital network to test the connection and configured responses between the cGas Detector and the DDC/BAS. You can do the same for relative humidity and temperature if the -RHT option is installed.

Enter passcode 2020 and press ENTER.

Enter Passcode  
2020

Navigate to the Testing parent menu and then to the Selected Channel menu item and press ENTER.

Choose Menu  
>Testing

Confirm the correct channel is showing. The list to choose from will depend on how many channels there are and what options are included:

- Gas Type (ie. CO)
- Gas Type (ie. NO2)
- Temperature
- Humidity

Selected Channel  
CO

Selected Channel  
>NO2

Enter the desired value and press ENTER.

Test Reading  
0 PPM NO2

Test Reading  
>10.0 PPM NO2

Press ENTER to confirm the value is correct.

Confirm?      N  
>10.0 PPM NO2      >Y

Test Reading  
10.0 PPM NO2

The test will start as soon as you press ENTER to confirm. To stop the test, press the UP or DOWN button.

### 5.8.3 Test Relay and / or Buzzer (if installed)

**NOTE:** Before testing the relay, notify the appropriate people so unnecessary distress or response is not caused by activating fans or equipment or inadvertently calling the fire department or other emergency response team.

Enter passcode 2020 and press ENTER.

Enter Passcode  
2020

Navigate to the Testing parent menu and then to the Selected Relay menu item and press ENTER.

Choose Menu  
>Testing

If you want test the relay, make sure the relay item is chosen. Change the value to the buzzer item if that is what you want to test.

Selected Relay  
Left SB Relay

Selected Relay  
>Left SB Buzzer

Navigate to the Test RLY menu item change Untripped to Tripped and press ENTER. You will hear a soft click and the relay will activate accordingly, respecting its failsafe setting. Or the internal buzzer will sound if you are testing the buzzer.

Test RLY: LSB RLY  
Untripped

Test RLY: LSB RLY  
>Tripped

To stop the relay test change the value to Untripped. You will hear a soft click and the relay will deactivate or the buzzer will go quiet.

Test RLY:  
>Untripped

## 6 TROUBLE SHOOTING

### **cGas Detector won't power up. (blank display)**

Is the power properly connected? Check the wiring connections. Refer to Section 4.4 *Wiring Connections*.

### **Display shows "SPAN FAULT" message.**

Check all connections and possible interferences and try a complete calibration procedure from the beginning again to see if this corrects the fault. If a second calibration does not resolve the fault then the sensor needs to be replaced.

Check to make sure the gas cylinder isn't empty.

### **Frequent, unexpected alarm signal sent to BAS/DDC.**

Check to see if EMI and RF interference is causing the equipment to react this way. Refer to Section 4.2.2 *EMI and RF Interference Considerations*.

**Display shows "COMM" message.** Modbus® or BACnet output signal has not been connected properly; will also occur if no requests are being made from the controller to the transmitter, ie addressing is not proper. Check the wiring connections and the network settings.

**Device cannot be seen by the Controller and/or the BAS / DDC on the Modbus® network.** Check the Baud rate. All devices in the network must have the same Baud rate.

- Check that local area network wiring is correct, especially the A and B lines to make sure they are not swapped between devices on the network.
- Check the Modbus® ID. Each device must have a unique ID assigned to it.

**Device cannot be seen by the Controller and/or the BAS / DDC on the BACnet® network.**

- Check the Baud rate. All devices in the network must have the same Baud

rate.

- Check to make sure the device has a unique ID assigned to it, the factory default is made up of the MAC ID and the Base ID.
- Check that local area network wiring is correct, especially the A and B lines to make sure they are not swapped between devices on the network.

**Error Codes.** The error code will appear on the display in place of the units for a channel.

### List of Possible cGas Error Codes:

CODE		DESCRIPTION
		The controller or BAs has not read the current gas concentrations in more than the preset time (default 5 minutes).
COMM	Communication Fault	<p>Could be an address Miss-matched between cGas and controller / BAS. MAC value on MODbus or MAC value or Device ID on BACnet</p> <p>Check for wiring problems. A and/or B wires broken at somewhere in the network or ground connection between cGas &amp; controller / BAS (using cable shield as ground is not recommended).</p>

F01	Negative Fault Reading	Check to make sure the smart sensor board is present and installed properly in the socket. If installed, the cGas detects the sensor signal is too far below its zeroAD. May be caused by a sensor that is temperature or humidity sensitive or the device wasn't warmed up for a minimum 24 hours. After an appropriate warm up period, zeroing the sensor will normally resolve this.
F03 F07 F11 F12	Sensor Faults	cGas cannot communicate with the sensor. Ensure the smart board is installed correctly. If unresolved, contact our Technical Support Department.
F02 F04 F09 F20	Smart Board Faults	Ensure the smart board is seated properly and installed on the correct side (left) if a single channel unit. If a power cycle does not resolve this, replace the sensor smart board.
F05	Error in reading Smart Board	cGas detected an error in the smart board ID. Use "Write to Sensor" for the indicated channel.
F06	SB ID Mismatch	Firmware expected a different smart board than what is in the sensor socket.
F07	RH & Temp Fault	cGas cannot communicate with the sensor. Ensure the smart board is installed correctly. If unresolved, contact our Technical Support Department
F08	DAC COMM	This is a hardware fault. Contact our Technical Support Department.

---

F30	AO DAC is not responding	cGas has detected a problem with its configuration or analog output (4-20 mA) a main board replacement may be required. Contact our Technical Support Department.
F80-99	Internal Memory Faults	The cGas has detected a configuration mismatch between cGas and installed sensors. Contact our Technical Support Department.

---



**SAFER AIR EVERYWHERE.**

[WWW.CETCI.COM](http://WWW.CETCI.COM)

CGAS-A|D-20251121-Rev-C|D

**Critical Environment Technologies™**

Unit 145, 7391 Vantage Way, Delta, BC V4G 1M3 Canada

Tel: +1.604.940.8741 Toll Free: +1.877.940.8741